

International Journal of Scientific Research and Reviews

Implementation of Internet of Things (IoT) Based Smart Logistics for Food Grain Industry

Murugaiyan Pachayappan*

Assistant Professor, Production and Operations Management,
Xavier Institute of Management & Entrepreneurship
Chennai, India

E-mail: pachayappanvn@gmail.com

ABSTRACT

Logistics plays a vital role for any organization. The logistic companies are focused to implement a best logistic management system for an effective product supply from the factory floor to the customer end. Recently, the logistic systems are incorporated with smarter devices like wireless sensor devices, radio frequency identifications (RFID) tags, temperature monitoring systems, global positioning systems (GPS) etc. to trace and track the product condition and location. By adapting these technologies, the risk factors associated with transportation of goods will be minimized. These technologies are independent to each other and they are decentralized system. The data and information transferred are not integrated to each other and the information control is ineffective. To overcome this problem a new internet based technology called Internet of Things (IoT) is emerged in the recent past. In this paper an IoT enabled smart logistic system for food grain industry is proposed. In the proposed design two-layer network architecture of IoT platform is introduced. The first layer is radio frequency identifications (RFID) act as an asymmetric tag-reader link and second is wireless sensor network (WSN) layer is an ad-hoc network between reader/master nodes. By adapting this smart logistic system achieves live monitoring of goods from shipment to customer place at lower cost of investment. The smart devices are connected via internet and real time data transfer will provide an opportunity for the food grain industry to react immediately if any instant changes required in the logistic process.

KEYWORDS: Internet of Things (IoT), Food Grain Industry, Smart logistic, RFID tag, Supply chain .

***Corresponding author**

Murugaiyan Pachayappan

Assistant Professor, Production and Operations Management,
Xavier Institute of Management & Entrepreneurship
Chennai, India

E-mail: pachayappanvn@gmail.com

INTRODUCTION

The flow of food grain goods has increased tremendously in the outline of varieties in goods, quality and quantity in goods, just-in-time delivery, globalization of marketing and seasonal variations etc. The logistic companies have undergone considerable changes in the process of transportation and needs a technological update in the logistics management. Intelligent logistics is the critical success factors for manufacturer and retailers. Effective logistics necessitates delivering the right product, in the right quantity, in the right condition, to the right place, at the right time, for the right cost and it has a positive impact on the success of the vendors in the supply chain. Tracking and traceability in the food supply chain have considered as a vital factor in the past few decades^{1,2,3}. Various food safety and traceability laws exist in several countries. European Union's General Food Law entered into force on January 1, 2005. The law included important elements like rules on traceability and the withdrawal of dangerous food grain products from the market. The important role of food grain industry is to adapt an accurate traceability and monitoring facility during transportation. Some food grains should be maintained in an accurate temperature and monitor the mitigation and risk factors during the transportation of products. In the perspective of consumer gives emphasis to safety, high quality and sustainability of products. To satisfy the consumer needs and demand, the companies are trying to adapt new trends in transportation and logistics. The lack of timely, accurate and inconsistent information transfer during transportation of food grain goods is the reason for the risk factors like product damage and wastages. As a result, it is difficult to obtain the real-time visibility and traceability of the current position of the goods in the overall supply chain. To overcome this difficulty, an Internet of Thing (IoT), a new emerging internet based technology was introduced. IoT is a global network infrastructure, which links the physical and virtual objects with the internet cloud. This linkage generates live data from the goods tagged with sensor devices in the smart container as shown in Figure 1 during transportation and communicates the updates to the concern location.

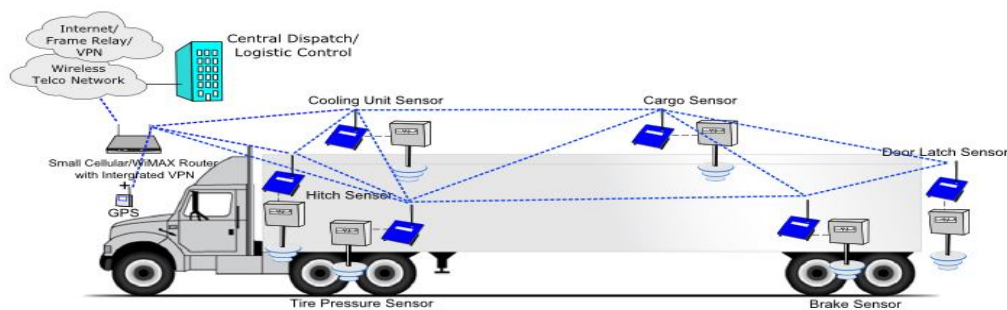

Figure 1: IoT enabled smart container

IoT offers specified object identification system and its current position in the global network. Radio frequency identification (RFID) and wireless sensing devices are considered as the key technologies enable IoT as a value creation system. In the future, RFID tags are equipped with sensors and other value added peripherals for interaction with their network, observe their surrounding environment as well as their geographical information. Such innovative tags with unique addressable identification number or IP address are attached on food grain packages. The logistic companies are really working in this perspective to achieve proper safety and secure distribution without damage of goods. The companies need to enrich their technological support for smart logistics. IoT is a viable technology for the food grain industry to trace and track the food grain package in the supply chain. In this paper two-layer network architecture is introduced to implement IoT in food grain industry. The rest of paper is organized as, in section 2 a literature review is carried out based on IoT in food grain sector. Section 3 illustrates an IoT-Architecture for food grain logistics, continued with sub-section 3.1 introduced a two-layer network architecture for IoT in food grain industry. Finally, section 5 deals with the conclusion and future research.

LITERATURE REVIEW

The IoT based technologies like RFID and wireless sensor network are the key technologies used for monitoring and tracking the live condition of the goods, present location of the goods and the concern delivery point. By adapting this intelligent tracking system achieve live monitoring of goods at lower cost of investment. The decision makers of the companies can react immediately based on the live data for any instant changes required in the food grain logistic process.⁴ RFID technology gains importance in logistics system, which helps to combine logistics control with logistics management. By adapting this technology, the efficiency of operating and managing is increased, enhances system's processing ability, helps make full use of manpower and decreases unnecessary loss and⁵ discussed the restricting factors for the implementation of IoT in Chinese logistics industry. Author identified the immature of technology in IoT, insufficient information security support system, implementation cost etc.^{6,7} the basic concept of Internet of Things (IOT) technology was discussed and elaborated its importance and significant for food grain logistics. Finally, the paper describes the implementation issues in IoT. Starting from the actual situation of the supply chain management, the article analyzed various aspects of the supply chain, and described the design of supply chain management system in intelligent logistics. At last, the trends and importance of the Internet of Things in intelligent supply chain logistics management was described.⁸ A methodology to minimize food losses by adapting intelligent food logistics was proposed and further, the paper describes the required technical solutions for IoT, such as the wireless sensor and

communication system for remote quality supervision, gas sensors to detect ethylene as an indicator of unwanted ripening and volatile components to indicate mould infections.⁹ Scheme for logistics tracking and monitoring based on internet of things was proposed to solve the problems of long transportation time, low transparency degree and high operation costs for logistics vehicle monitoring and tracking system.¹⁰ Author analyzed requirements and conceptualize monitoring and analytics as a service for grain warehouses, with a focus on Vietnam's environment. By utilizing the technologies like cloud computing, data analytics and Internet of Things (IoT) they proposed a conceptual model to monitor various important information for grain warehouses and present different data analytics services. From the above literature it's very clear that many researchers have focused on developing a smart framework for food grain logistic sector. Many research works focused on real time monitoring system of food grain goods. There is very fewer research work focused on incorporation of IoT technology with smart sensory devices for food grain logistics. So, in this research paper an IoT enabled logistics system for food grain industry is proposed.

IOT – ARCHITECTURE

The IoT architecture is generally divided into three layers: the perception layer, the network layer, and the service layer, as shown in Figure 2. Perception layer: It is the core layer of IoT, it can also have called as data extraction layer. All kinds of data and information are gathered from the physical devices, by the technologies of sensors devices, RFID tags and reader-writers, wireless sensors network (WSN), intelligent terminals, camera, global position system (GPS), electronic data interface (EDI), mobile etc. Network layer / Transport layer: The data extracted from the perception layer are sent to the network layer. The network layer is a data transmission layer. The network layer enriches various technologies like wireless sensor network (WSN), mobile communication network, radio access network, and other communications equipment, such as global system for mobile communications (GSM), general packet radio service (GPRS), wireless fidelity (WiFi), worldwide interoperability for microwave access (WiMax), Ethernet, etc., this layer provide an effective, reliable and trusted network infrastructure platform to large scale industry application.

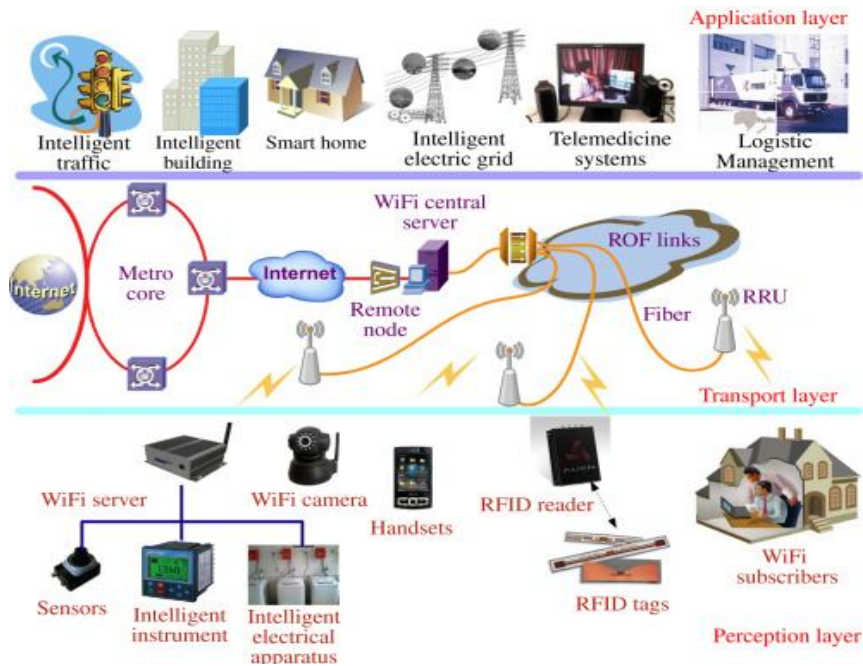

Figure 2: IoT Architecture

Service layer / Application layer: The data transferred from the network layer is stored and managed in the service layer. This layer includes two different sub-layers viz. data management sub-layer and application service sub-layer. The data management sub-layer process the complex data and uncertain information, such as screening, restructuring, cleaning and combining, and provides directory service like market to market (M2M) service, Quality of Service (QoS), geometrics, etc. by service oriented architecture (SOA), cloud computing technologies, and so on. The application service sub-layer translates the collected data to meaning full information of content and provides good user interface for enterprise application and end users, such as logistics and supply, disaster caution alert, environmental monitoring, agricultural, production, and so forth.

PROPOSED TWO-LAYER NETWORK ARCHITECTURE FOR IOT-FOOD GRAIN LOGISTIC

To realize the IoT-Food grain logistic system, which is able to constantly monitor and track the product quality and safety during the whole supply chain from production to customer, there are several requirements have to be considered. They are visibility, traceability, accuracy and controllability of the goods should be smartly governed at all levels of packaging or carriers. RFID with multi capacity in terms of sensing functionalities, energy sourcing and saving capacities, processing and storage capacities and wireless sensor interfaces can be installed in the containers as

shown in the Figure 1. According to the nature of the goods and mode of transportation, the RFID can be either chipless RFID tags, or reusable such as active wireless sensor nodes.

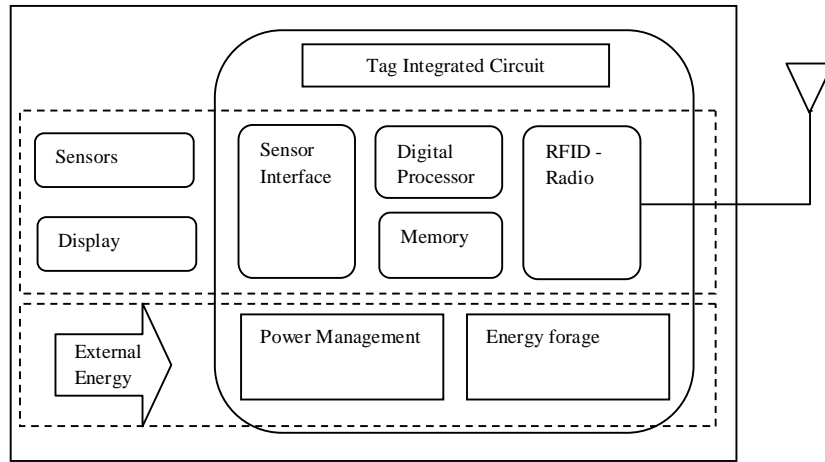

Figure 3: Intelligent RFID Tag

For the IoT platform the traditional RFID cannot cope with these entire configurations. Therefore, a networked platform which embraces varieties of sensor devices and different classification of tags with heterogeneous radio interface and functionalities are required.

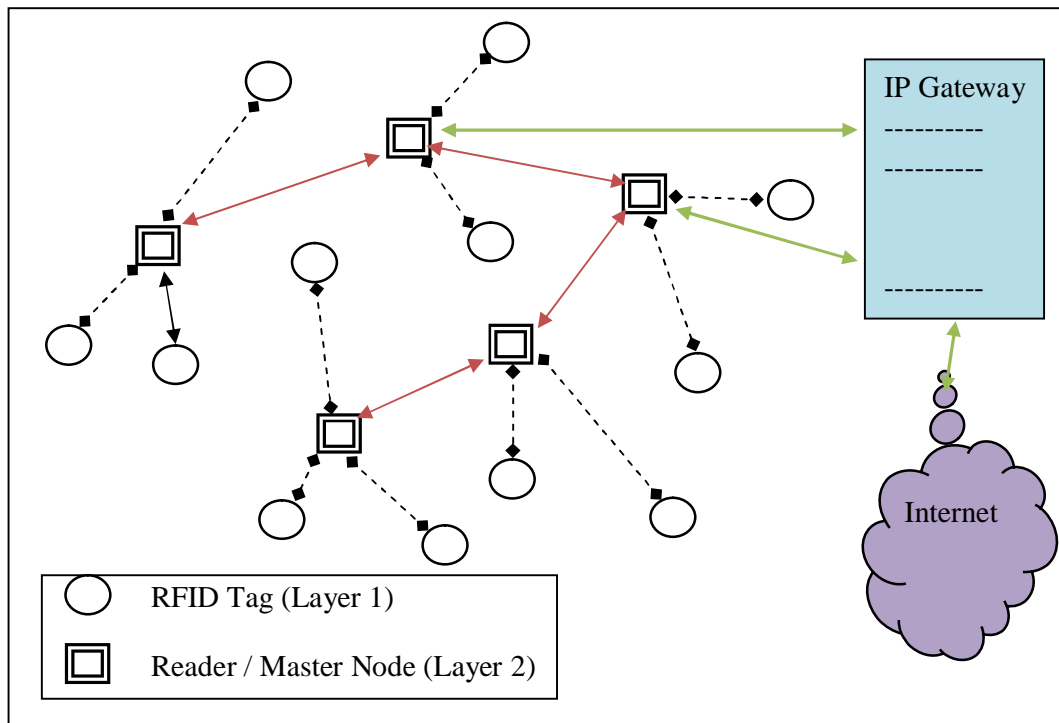

Figure 4: RFID tag and reader node with a hierarchical two-layer network

The intelligent RFID tag as shown in Figure 3 and the two-layer network architecture are shown in Figure 4 are distinctive for food grain logistics. In Figure 4, RFID layer is the first layer which acts as an asymmetric tag-reader link. The second layer is wireless sensor network layer which act as an ad-hoc network between master nodes. RFID tags are coordinated by master nodes (Layer 2). In layer 2, ad-hoc networks are self-organized between master nodes as a wireless sensor network. RFID layer is a mixed (heterogeneous) network with asymmetrical links provides a large range of RFID selections. Smart RFID tags are ideally embedded in grain packages and communicate with a reader (master) by micro power wireless links. The smart RFID tag as shown in Figure 3 is normally consists of a power management and energy forage, digital processor, sensor interfaces and memory and a radio transceiver.

The radio interface in the RFID consists of near-field coupling or far-field backscattering in high frequency (HF) or UHF bands. For instance, an RFID tag incorporating with Ultra-wideband (UWB) technologies applicable for high-speed detection, accurate positioning and time-domain sensing. Even a printed chipless tag with inbuilt sensing characteristics through RF measurements of the impedance changes as a response to the varying environment.

Tags and sensors (Figure 4) in this layer are inexpensive and energy-efficient under energy autonomy conditions. The master node is a reader to collect the data from the tag and link to the Internet cloud through standard air interfaces like WiFi, WiMax, GSM/GPRS and 3G. The master node should be a superior wireless sensory location, which is regularly equipped with sophisticated sensors such as imaging sensors and motion sensors as well as GPS for geographical tracking. The proposed two-layer network architecture links the objects (goods, vehicle etc) via internet to transfer the real time data for the purpose of realizing intelligent detection of objects, namely object current location/status, tracking, monitoring and management, with the help of RFID tags, sensor devices, actuators and positioning devices. By taking this as an advantage, IoT is a unique platform to monitor the real time status of the grain goods in the value chain. As such, this paper proposes an intelligent tracking system for the food grain logistics by integrating IoT technologies.

CONCLUSION

The global communication and information technology have shown a vast development. IoT is an emerging communication technology, which communicates between people and physical things and even between things themselves. IoT based logistic plays a vital role for vehicle monitoring, dynamic distribution, monitoring the goods condition during transportation, reducing the damage level, wastage level etc. considering these factors lead to the success of intelligent logistic system. In

addition, the paper proposed two-layer network architecture of IoT platform. The first layer is radio frequency identifications (RFID) and second is wireless sensor network (WSN) layer. By adapting the proposed system, the grain logistic companies can easy track and monitor the goods during transportation. This system will avoid the physical damages and wastages and increase the efficiency of a logistic system. The future research will be focused on field testing and examines the efficiency of proposed system.

REFERENCES

1. Carriquiry M, Babcock BA. Reputations, market structure, and the choice of quality assurance systems in the food industry. *American Journal of Agricultural Economics*. 2017; 89(1):12-23.
 2. Folinas D, Manikas I, Manos B. Traceability data management for food chains. *British Food Journal*. 2006; 108(8): 622-633.
 3. Jansen-Vullers MH, Van Dorp, CA, Beulens, AJ. Managing traceability information in manufacture. *International Journal of Information Management*. 2003; 23(5): 395-413.
 4. Er Z, Lian, FY, Lian, JG. An RFID-based Automatic Identification System on Modern Grain Logistics. In *Management of e-Commerce and e-Government*. ICMECG'08, 2008; 10-13.
 5. Guang-hua, ZHAO. Application of IOT in Logistics Industry: Restricting Factors and Countermeasures. *Logistics Technology*. 2011; 17.
 6. Xu B, Zhang D. Yang W. Research on architecture of the Internet of Things for grain monitoring in storage. In *Internet of Things*. 2012: 431-438.
 7. Zhang FZ, He HX, Xia WJ. Application Analysis of Internet of Things on the Management of Supply Chain and Intelligent Logistics. In *Applied Mechanics and Materials*. 2013; 2655-2661.
 8. Jedermann R, Nicometo M, Uysal I, Lang W. Reducing food losses by intelligent food logistics. *Philosophical Transactions of the Royal Society of London A: Mathematical, Physical and Engineering Sciences*. 2014; <http://dx.doi.org/10.1098/rsta.2013.0302>
 9. Dong CA. scheme for logistics tracking and monitoring based on internet of things. *Computer Modelling and New Technologies*. 2014; 18(12b): 283-292
 10. Cao TD, Truong HL. Analyzing and Conceptualizing Monitoring and Analytics as a Service for Grain Warehouses. In *Recent Developments in Intelligent Information and Database Systems*. Springer International Publishing. 2016; 161-171.
-