

International Journal of Scientific Research and Reviews

Front Truncated Novel Dielectric Rectangular Slab Antenna for Better Impedance Matching and Directive Gain without Increasing the Radiating Slab Size

Singha Roy Pritam *

Pacific Academy of Higher Education & Research University, Udaipur, Rajasthan-313003, India ,E-mail:prittam.pritam@gmail.com

ABSTRACT

An open ended solid rectangular front truncated dielectric rectangular waveguide fed by standard metallic rectangular waveguide operating in TE_{10} mode is presented in this chapter. Computer simulation results using full wave solver HFSS (An soft Corp.) on the radiation characteristics of a rectangular dielectric waveguide antenna as function of its length and dielectric constant has been reported .It is apparent that a practicable length of the slab cannot be used to achieve acceptably low return loss along with directive radiation pattern. To solve the problem, introduction of a truncated pyramid in front of radiating aperture, without increment of the physical size of the radiating dielectric slab is proposed in this section and results obtained for the same are presented.

KEYWORDS: Rectangular Slab Antenna, Impedance match, Radiating Slab.

***Corrospoding Author:**

Pritam Singha Roy

Department of Electronics & Comm. Engineering,
Pacific Academy of Higher Education & Research University,
Udaipur ,Rajasthan-313003, India
E-mail:prittam.pritam@gmail.com

INTRODUCTION

An open ended solid rectangular dielectric waveguide fed by standard metallic rectangular waveguide operating in TE₁₀ mode is one of the simplest dielectric antennas. However, to use such radiators as practical antennas, matching of the radiator to the metallic waveguide launcher is important. From the earlier works it is apparent that a practicable length of the slab cannot be used to achieve acceptably low return loss along with directive radiation pattern. To overcome these limitations, modification to the basic structure has been introduced successfully in this section.

Front Tapered Dielectric Rectangular Slab Antenna Design Methodology

The solid rectangular dielectric waveguide, henceforth simply called the dielectric waveguide, is possibly one of the simplest dielectric antennas. This is particularly true if one thinks of the standard metallic rectangular waveguide operated in the TE₁₀ mode as the feeder (or launcher). Figure 1 shows a possible configuration of such an antenna where the external dielectric waveguide dimensions are the same as the internal dimensions of the metallic waveguide.

Unlike metallic walls, boundary conditions at dielectric walls do not require the tangential component of the electric field to vanish. One is thus led to expect improved radiation pattern symmetry for the dielectric waveguide. Additionally, since the field in the dielectric waveguide extend beyond the dielectric boundaries, increased directivity (compared to the waveguide free end) should also be expected. The first work on the dielectric waveguide antenna, then commonly referred to as the polyrod antenna, is attributed to G.C. Southworth in 1940. A few years later in a paper² describing the work done from 1941 to 1944 at Bell Telephone Laboratories, Holmdel, New Jersey, Mueller approached the design of a dielectric waveguide antenna of uniform rectangular cross section by “establishing analogies with array theory, coupled with existing knowledge about transmission in uniform dielectric wires”.

A standard rectangular dielectric slab antenna with properly designed length (8.85 mm corresponding to $\lambda_g/4$ at 10 GHz for Teflon having $\epsilon_r=2.1$) of the pyramidal taper matching section at the wave launching end has been designed (Figure 1), investigated practically and found not to give significant matching of the antenna to the WR90 X-band waveguide launcher.

The radiation patterns were also found to be non-directive. The cross-polar isolation was noted to be about 20 dB. It seemed that the radiation characteristics couldn't be improved significantly without making the slab impracticably long and bulky.

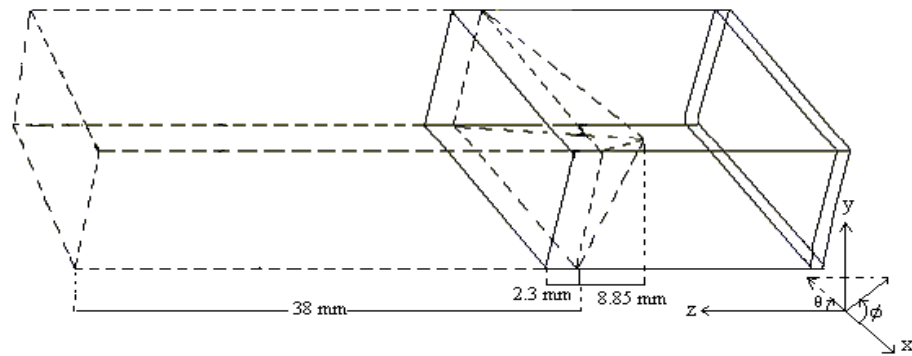

Figure 1. Dielectric slab antenna with pyramidal matching section (without front tapering)

Accordingly, a unique approach was adopted by creating an extended pyramidal shaped taper in front of the antenna (Figure 2). These resulted in better directive radiation pattern and at the same time huge improvement in spot frequency return loss as well as dual frequency operation³⁻⁵. The pyramidal extension in the front end of the radiating slab not only provided a better directive beam pattern but more importantly acted probably as an impedance matching transformer between the dielectric slab and free space. All these results have been simulated using FEM based simulation software HFSS⁶ and tested experimentally to validate the outcomes.

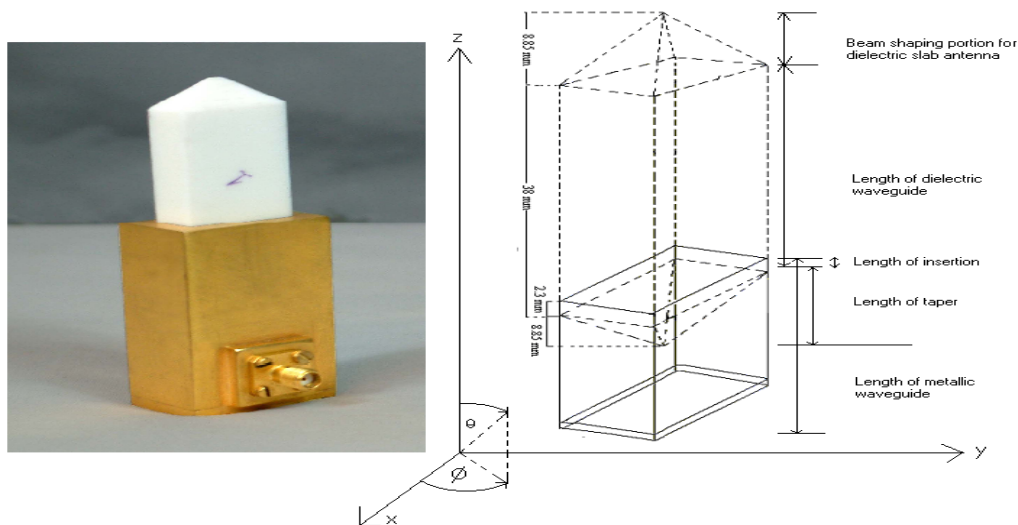

Figure 2: Dielectric Slab antenna with pyramidal matching section

RESULTS

Use of a pyramid shaped taper at the front edge of the radiating dielectric slab antenna gives extra control for ensuring better directive radiation pattern without any unwieldy increment of the length of the slab which may make the antenna bulkier. In turn it causes realization of dual band operation with a huge improvement in return loss in one frequency and a comparatively lower return loss with much wider 2:1 VSWR bandwidth (corresponding to ~ -9.5 dB return loss) in the other.

The return loss plots of rectangular dielectric slab with and without pyramid shaped taper at the front end are given in figures 3 and 4 respectively. These show experimentally measured return loss of about -16.51 dB at 9.67 GHz and 2:1 VSWR bandwidth of about 400 MHz for the former case, which changes for the latter case to -23.79 dB at 8.51 GHz .

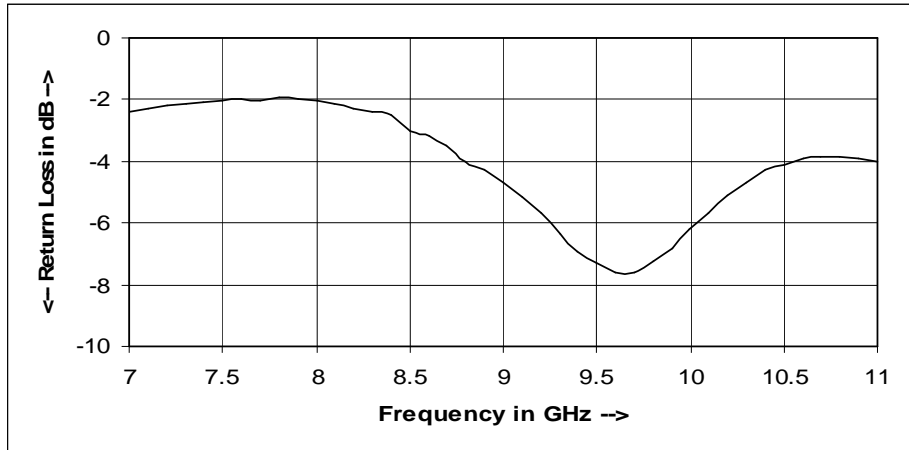

Figure 3. Simulated return loss plot for antenna without taper at front

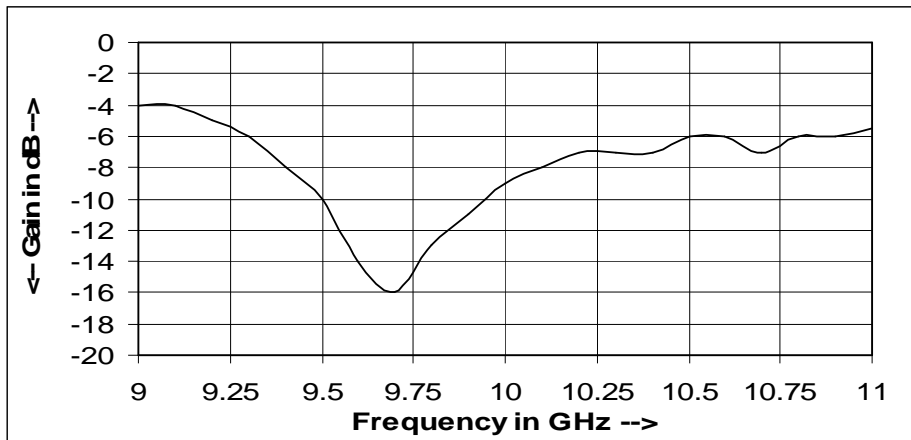

Figure 4: Measured return loss plot for antenna without taper at front

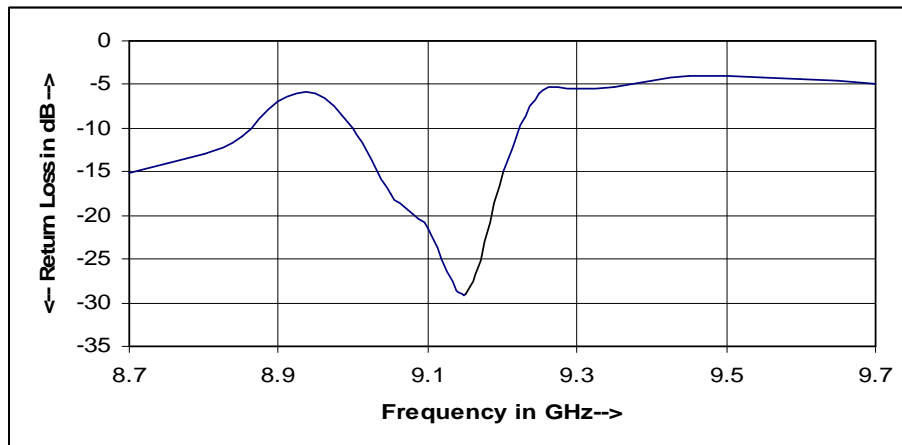

Figure 5: Simulated Return loss plot for antenna with taper at front (Figure 2)

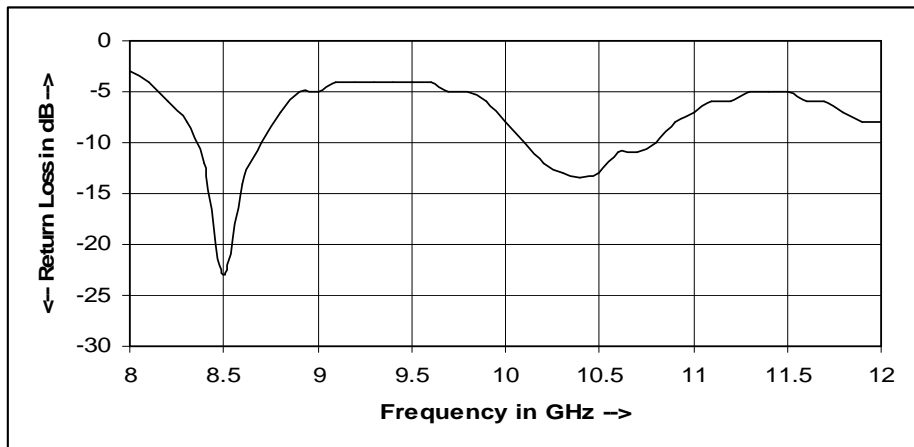

Figure 6: Measured return loss plot for antenna with taper at front (Figure 2)

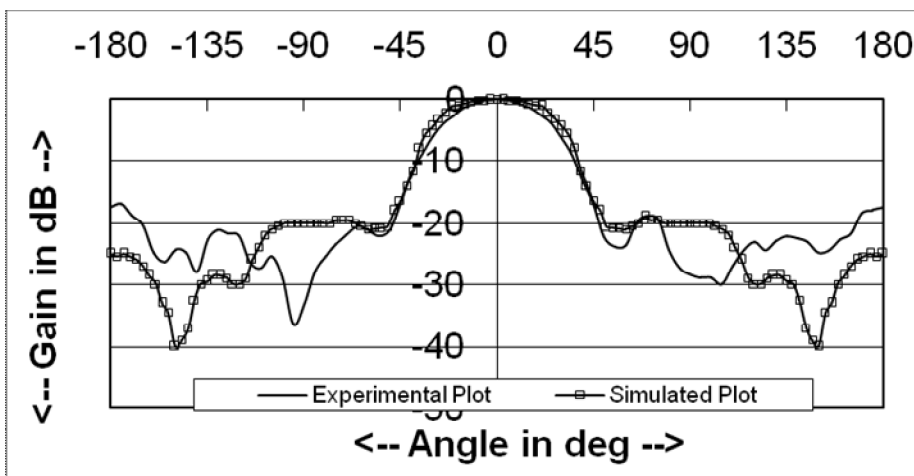

Figure 7: Simulated and experimental E filed radiation patterns for antenna without taper

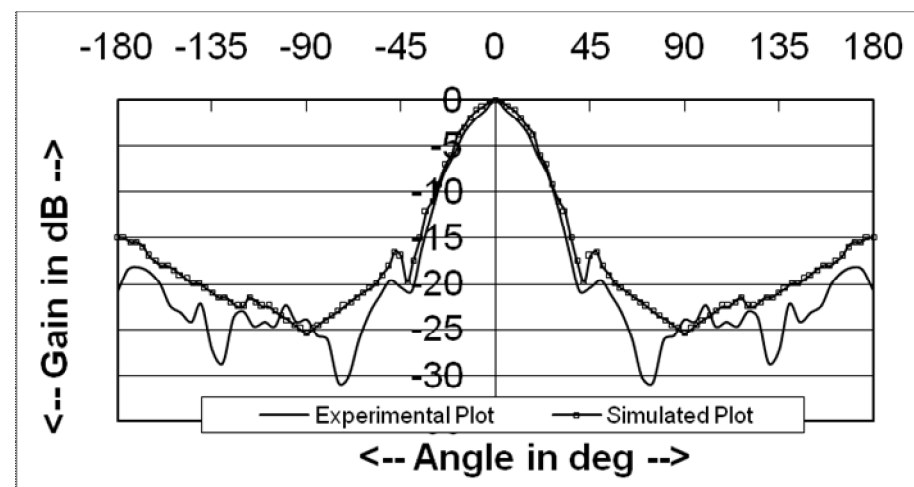

Figure 8: Simulated and experimental E filed radiation patterns for antenna with taper

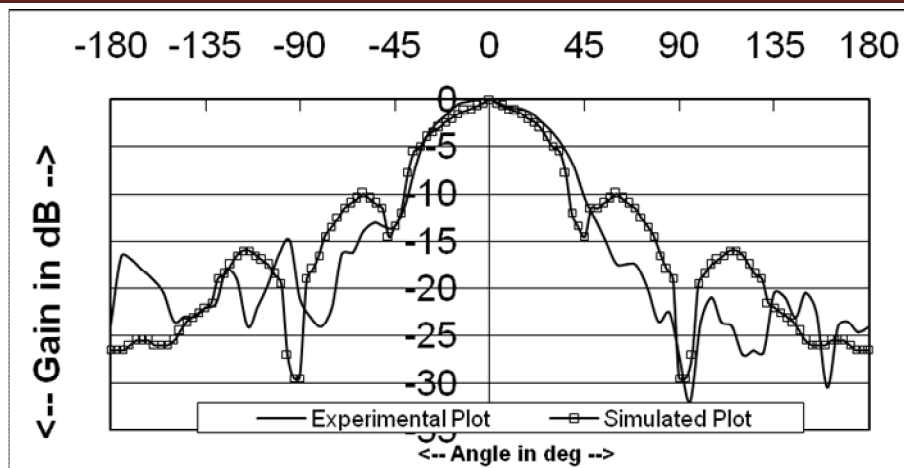

Figure 9: Simulated and experimental H filed radiation patterns for antenna without taper

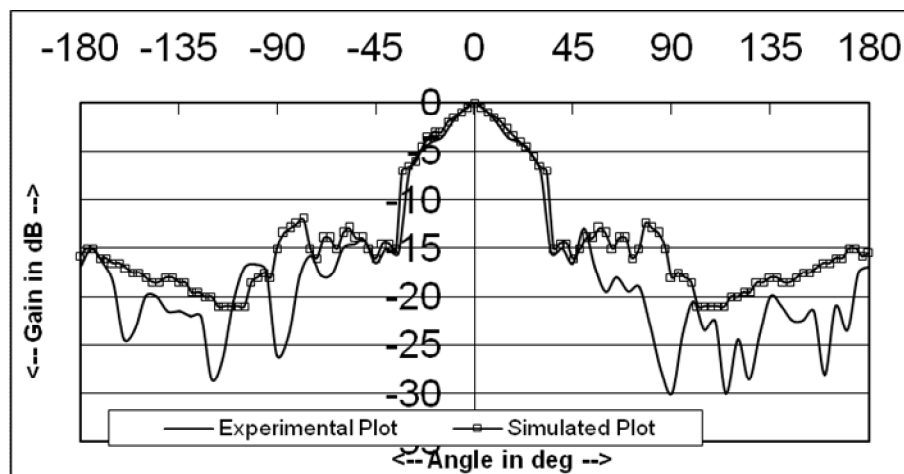

Figure 10: Simulated and experimental H filed radiation patterns for antenna with taper

with 2:1 V.S.W.R. bandwidth of about 400 MHz and -13 dB at 10.4 GHz with 2:1 VSWR bandwidth of about 700 MHz. The radiation patterns are also found to improve in terms of directivity in both E and H planes by the insertion of a pyramidal taper at the front end of the slab as shown in figures 5 to 10. The improvement could have been even better had the taper length been more. It is further observed experimentally that the cross-polar isolation remains at more than 20 dB with or without insertion of the frontal section.

Impedance Matching and Directive Gain without Increasing the Radiating Slab Size

A standard rectangular dielectric slab antenna with properly designed length (8.85 mm corresponding to $\lambda_g/4$ at 10 GHz) of the pyramidal taper matching section at the wave launching end has been investigated (Figure 11). It seemed that the radiation characteristics couldn't be improved significantly without making the slab impracticably long and bulky. So truncation of the front aperture to create a hollow pyramidal structure therein was attempted. In fact the truncations from the aperture of the dielectric slab antenna give reduction of weight.

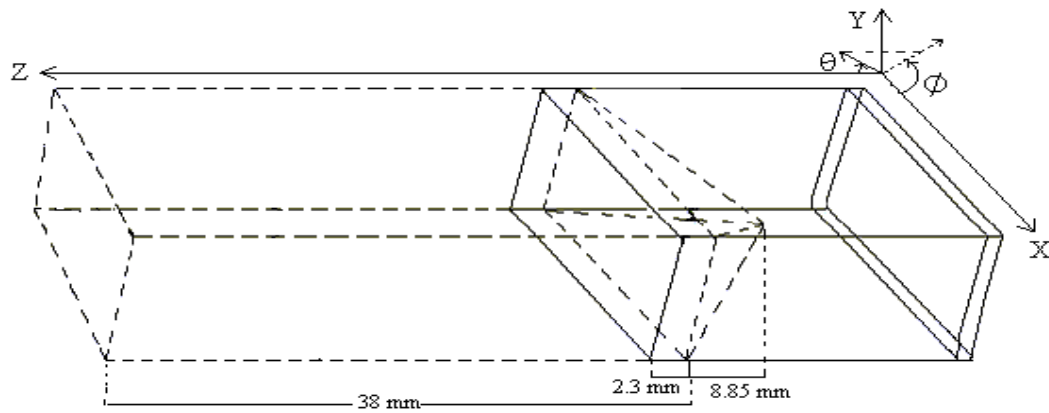

Figure 11. Dielectric slab antenna with pyramidal matching section

The length of the radiating dielectric slab is 38 mm long and the width and breath of the dielectric slab antennas are 22.86 mm and 10.16 mm respectively. In the front truncated dielectric slab antenna (shown in Figure 12), the dimension of the truncated pyramid is 16.86 mm and 4.16 mm for the width and breadth respectively. The length of the truncated pyramid is 17.7 mm. A unique approach was adopted by creating a pyramidal shaped hollow in front of the antenna (Figure 12), which resulted in better radiation patterns with appreciable reduction in side lobe level and at the same time a huge improvement in spot frequency return loss as well as 2:1 VSWR bandwidth (corresponding to ~ -9.5 dB return loss) as shown in figures 3.28 to 3.30.

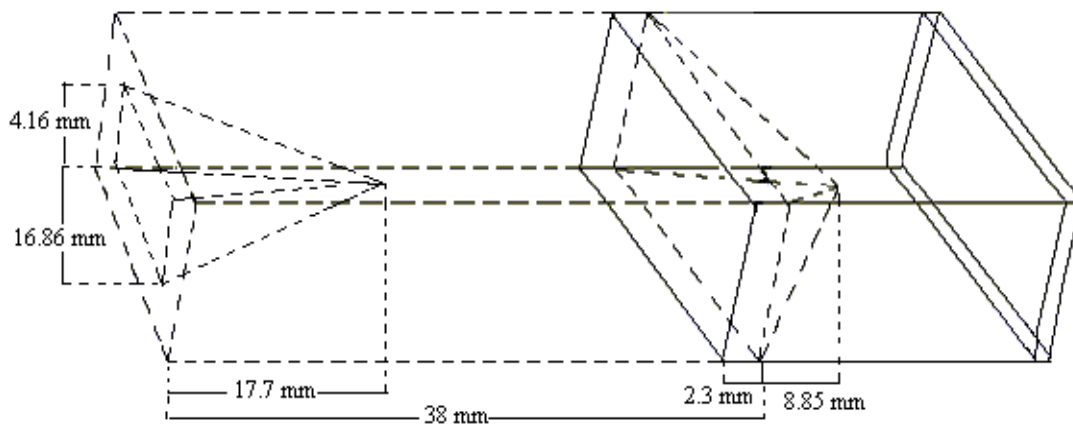

Figure 12: Dielectric slab antenna with pyramidal matching section and a hollow pyramid

The extra aperture in the front end of the radiating slab not only provided a better directive beam pattern but also most importantly is acted as an impedance matching transformer between the dielectric slab and free space which caused huge improvement in both impedance and radiation characteristics simultaneously.

RESULTS

All the investigations have been carried out in the form of electromagnetic simulation using HFSS.

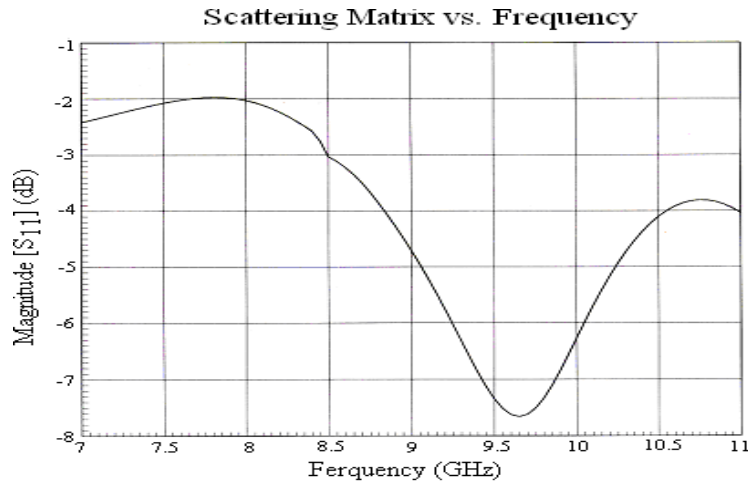

Figure13: Return loss pattern

For the dielectric slab antenna shown in figure.11 significant matching of the antenna to the WR90 X-band waveguide launcher (Figure 13) was not achieved. The pattern was also found to be having large side lobes and consequently limited usefulness for directive applications (Figures 16 and 18).

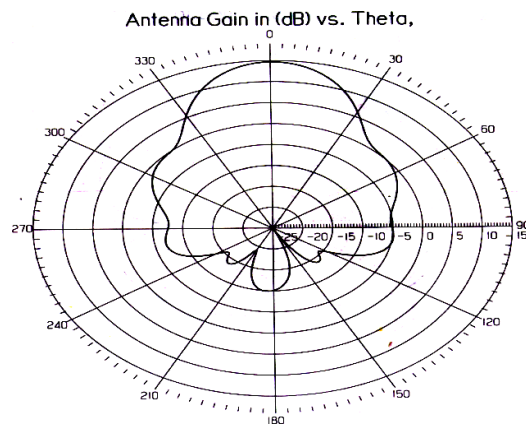

Figure 14: Radiation pattern for antenna 1 at $\Phi = 0^\circ$ at resonant frequency

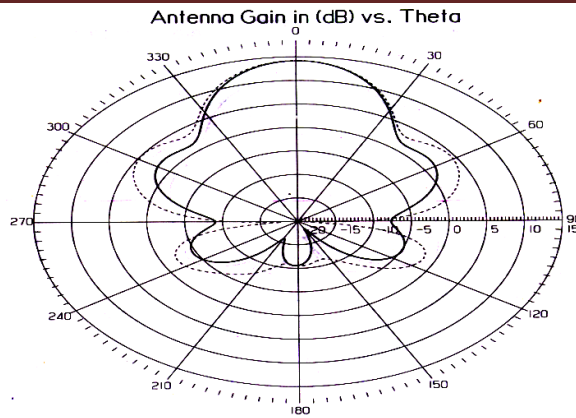

Figure 15: Radiation pattern for antenna 1 at — $\Phi = 45^\circ$ and - - $\Phi = 90^\circ$ at resonant frequency

In case of the truncated pyramidal shaped hollow inserted in front of the antenna 2:1 VSWR bandwidth (corresponding to ~ -9.5 dB return loss) shown in Figures 16 to 18.

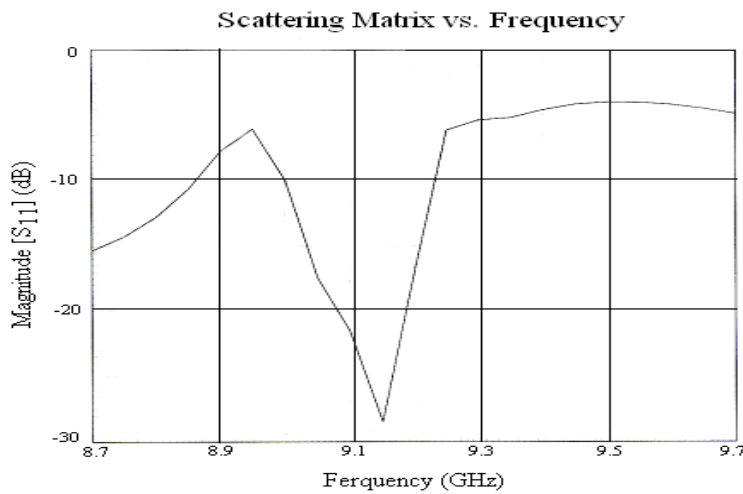

Figure 16: Return loss pattern for antenna

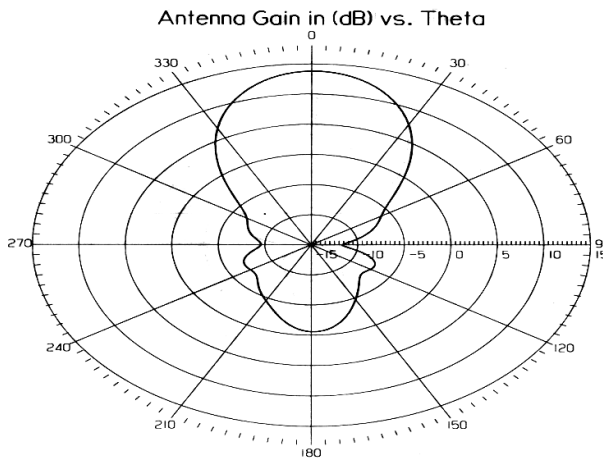

Figure 17: Radiation pattern for antenna 2 at $\Phi = 0^\circ$ at resonance frequency

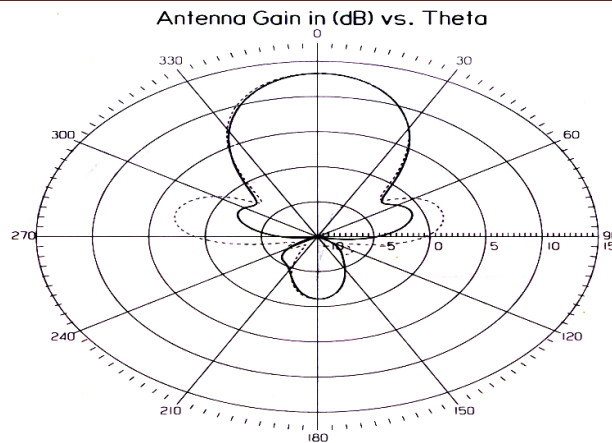

Figure 18: Radiation pattern for antenna 2. at — $\Phi = 45^\circ$ and - - $\Phi = 90^\circ$ at resonance frequency

Use of a truncated pyramid shaped hollow at the front edge of the radiating dielectric slab antenna thus gave extra control for ensuring better directive radiation pattern without any side lobe and with negligible back lobe level. The return loss plots of standard rectangular dielectric slab and rectangular dielectric slab with pyramid shaped hollow at the front end as given in figures 13 and 16 respectively, show a return loss of about -7.7 dB at resonance for the former case, but about -28.5 dB at resonance along with 2:1 VSWR bandwidth is about 250 MHz for the latter. The radiation patterns are also found to improve drastically by the pyramidal truncation at the front end of the slab as shown in figures. 17 and 18. From figures 17 and 18 it is seen that radiation patterns become more directive without any side lobe by introduction of the truncated front-end taper. In comparison, side lobes about 15 dB down from the main beam occurring at nearly 54° and 306° on both sides of the main lobe are clearly visible in figures 13 and 14 for the standard dielectric slab antenna without any modification.

CONCLUSION

The introduction of pyramidal taper in the front radiating face with adjustable properties (length and base area of the introduced pyramidal taper section) can give similar directive beam without undesirable increase in length and at the same time it shows dual frequency operation. An appropriate approach of truncation in the front radiating edge with adjustable properties (length and base area of the truncated pyramidal hollow section) can give improved directive beam without undesirable increase in length and at the same time huge improvement in bandwidth and impedance matching. All these give our proposed antenna competitive advantage for trans-receiver applications over standard dielectric slab antennas.

REFERENCES

1. Waveguide Antenna”, Proceedings of APSYM, Cochin, India, Dec. 9-11, 2002; 315-318.
 2. HFSS, Maxwell^R Software, Ansoft Corporation, Four Station Square, Suite 660, Pittsburgh, PA 15219, USA.
 3. Clarricoats, P.J.B., and Salema, C.E.R.C., “Propagation and Radiation Characteristics of low Permittivity Dielectric Cones”, Electronic Letters, 1971; 7(17): 483-485.
 4. Clarricoats, P.J.B., and Salema, C.E.R.C., “Radiation Charecteristic of Dielectric Cones”, Electronic Letters, 1972; 8(16).
 5. Salema, C.E.R.C., “Theory and Design of Dielectric Cone Antennas”, Ph.D. Thesis, University of London, 1972.
 6. HFSS, Maxwell^R Software, Ansoft Corporation, Four Station Square, Suit 660, Pittsburg, PA 15219, USA
 7. Vedavaty, T.S., “Dielectric Coated Spherically Tipped Metal Cone Aerials Excited in Unsymetric Hybrid Mode”, Ph.D. Thesis, Indian institute of Science, Bangalore, India, 1972.
 8. Chatterjee, R., and Vedavarty, T.S., “Dielectric Coated Spherically Topped Conducting Cone Aerials Excited in Un-symmetric Hybrid Mode at Microwave Frequencies”, Journal of the Indian institute of Science, 1975; 57(11): 399-425.
-