

International Journal of Scientific Research and Reviews

Speed control of Brushless DC Motor using Artificial Neural Network

Mamatha N. *, Srinu I. and Kumar M. V. Chandra

¹Electrical and Electronics Engineering, Pragati Engineering College, Surampalem, A P, India.
mamatha.nm11@gmail.com¹, sreenuinjetti@gmail.com², muppina.chandu@gmail.com³

ABSTRACT

BLDC motor has surpassed other motors as the demand for high efficiency, high power factor, precise speed and torque control and low maintenance increases. BLDC motor has become predominantly significant in applications such as electric trains, electric automotive, aviation and robotics. Since the BLDC motors do not require a commutator and due to its transcendent electrical and mechanical attributes and its ability to work in risky conditions it is more reliable than the DC engine. There are a lot of parameters which need to be in focus while talking about a speed controller performance like starting current, starting torque, rise time, etc.,. This paper presents the design and performance and the comparative analysis between the speed control of electronically commuted Brushless DC motor (BLDC) using conventional controllers like Proportional Integrative (PI) controller, Fuzzy PI controller, Artificial Neural Network speed controllers for the BLDC motors will be proposed. A simulation study is conducted to evaluate the efficiency of the proposed speed controllers. Further, a comparative study is performed to validate the system effectiveness. The response of the system can be observed from the above controllers with the help of MATLAB / SIMULINK.

KEYWORDS—BLDC Motor, Speed Control, PI Controller, Fuzzy Controller, Artificial Neural Network controller

***Corresponding Author:**

N. Mamatha

PG Scholar,

Electrical and Electronics Engineering,

Pragati Engineering College,

Surampalem, Andhra Pradesh, India,

E Mail –mamatha.nm11@gmail.com

I. INTRODUCTION

The rapid requirement of motor drives with the new technology in the various industries is increases day by day. There is great demand for efficient variable speed, long term stability and good transient performance of motor drives. The dc motor may be categorized according to the commutation circuit. One is traditionally DC motor which is mechanically commutated and other is Brushless DC motor (BLDC) having an electronically commutated with sensor or sensor-less system.

The BLDC motor has a rotating permanent magnet and stationary armature¹. Brushless DC Motors (BLDC) are widely used in many applications such as automotive, computer, industrial, aerospace etc. BLDC Motors have several advantages over brushed DC Motor. They have lower maintenance due to the elimination of the mechanical commutator and they have a high power density which makes them ideal for high torque to weight ratio applications. Compared to induction machines, they have lower inertia allowing for faster dynamic response to reference commands. Also, they are more efficient due to the permanent magnets which results in virtually zero rotor losses. It has many advantages such as simple structure, high reliability, small size, high torque and simple structure. It is mainly applicable for high performance drives.

Generally the performance of motor is affected by sudden change in unknown load or speed. But as the BLDC motor drives are nonlinear in nature, they require an improved or modified controller that can adapt a nonlinear condition and achieve the desired performance². So to encounter this problem controller is required. Because of the simplicity in tuning, the PI controller are until now are mostly useful controller in industries.

The PI controller is carried out from the input and feedback signal. And then this error passes through the proportional integrative function one by one, so that the speed error can be reduced and get the desired performance³. But this controller is fails to operate in dynamic conditions. Also it has some operating condition issue. While comparing with the Fuzzy logic controller, PI controller takes large number of peak overshoot that affects the system performance. The Fuzzy tuned with conventional PI controller improves the dynamic as well as steady state behavior and also it improves the system performance.

Although most industrial control systems depend on PI controllers, most of these applications are nonlinear (like temperature control), and PI tuning for nonlinear systems is very difficult⁹.

On the other hand, Fuzzy PI controllers can be used for nonlinear systems, but it need good knowledge of the system for tuning. Most fuzzy controllers use a rectangular membership

function and two fuzzy sets or more can be used. The more fuzzy sets used the more stability and better performance achieved, but also more complexity the system becomes. But An ANN is based on a collection of connected units or nodes called artificial neurons which loosely model the neurons in a biological brain, can be tuned for many inputs without complexity. Overcomes the disadvantage of both PI and Fuzzy PI controller and improves the system stability

Basically the use of controller is to obtain actual speed of motor into reference speed which we actually required. The proposed system are analyzed with the help of MATLAB / SIMULINK results and compared with PI controller, Fuzzy Logic Controller and ANN.

II. CONVENTIONAL PI CONTROLLER

Proportional& Integral Controllers were developed because of the desirable property that systems with open loop transfer functions of type 1 or above have zero steady state error with respect to a step input.

Proportional action: responds quickly to changes in error deviation. Integral action: is slower but removes offsets between the plant's output and the reference.

The target from any controller is to minimize the error between the actual output, which needed to be controlled, and the desired output, which is called the set point. In the case of speed control this error can be expressed by the following equation

$$e(t) = \omega_{sp}(t) - \omega_{pv}(t) \quad \dots (1)$$

Where $e(t)$ is the error function of time, $\omega_{SP}(t)$ is the reference speed or the speed set point as function of time, and $\omega_{PV}(t)$ is the actual motor speed as function of time. The PI term stands for Proportional Integral Derivative, so any PI controller can be divided into 3 parts each part has its Gain, the first part is the proportional part which is the error multiplied by a constant gain which is K_p . The second part is the integral part, which is the integration of error with time multiplied by a constant gain, which is K_I . The third part is the derivative part, which is the derivative of error with time multiplied by a constant gain which is K_D .

The P controller utilizes the gain K_p and produces the output which is proportional to the current error value. If the proportional gain is high then the system becomes unstable. In order to make the system performance stable, integral action is to be taken. This integral mode is used to accumulate steady state error which is caused by proportional action and providing slow response. The derivative mode response to the rate at which error is changing. But due to the derivative action noise will be formed. Hence we will control the speed of BLDC motor by using only Proportional Integrative (PI) Controller which is governed by the following equation. The PI controller equation can be expressed as the following

$$u(t) = K_P e(t) + K_I \int e(t)dt \dots (2)$$

Where $u(t)$ is the PI output, K_P is the proportional gain, K_I is the integral gain, K_D is the derivative gain, and $e(t)$ is the error function shown in equation (1). The following function block, in figure 1, explains the operation of the PI controller.

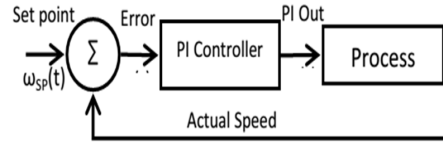

Fig 1: Pi controller block diagram

According to [9], there are two main parameters which should be minimized by the control system:

- Rise time (T_r): defined as the time taken to go from 10% to 90% of the targeted set point value.
- Settling time (T_s): defined as the time required for the response curve to reach and stay within a range of certain percentage (usually 5% or 2%) of the final value.

There are more parameters which should be taken into account in case of motor speed control, like start up current, start-up torque, and speed variation percentage. So any controller, PI controller or fuzzy PI controller, target to reduce the rise time, settling time, steady error, and overshoot.

III. FUZZY PI CONTROLLER

Fuzzy controller is a logistic controller based on fuzzy logic. It is a rule based decision making method which is used to process that a human can control with expertise gain from the experience Fuzzy controllers depends on rules and conditions between inputs to get the output.

Fuzzy controllers rules are in terms that human can understand like tall, short, medium height, so it is easier for human to design if he has a well knowledge about the system that needed to be controlled.

The inputs of the fuzzy controller are mapped to certain values called Fuzzy sets. Any fuzzy controller consists of three parts

- Fuzzification: It is the process of converting the analogue input to one of the values of the fuzzy sets using a membership function.
- Rule Base: Are the logistic rules or conditions between the inputs to get the output.
- Defuzzification: It is the process which convert the system output from the fuzzy sets values to analogue output value.

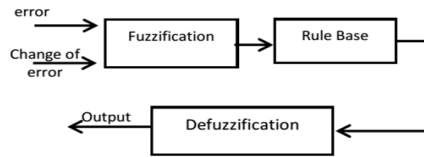

Fig 2: Fuzzy Block Diagram

Most fuzzy controllers use a rectangular membership function and two fuzzy sets or more can be used. The more fuzzy sets used the more stability and better performance achieved, but also more complexity the system becomes. In case of 5 fuzzy sets, the fuzzy sets may be called Negative Big NB, Negative N, Zero Z, Positive Bid PB, and Positive P.

IV. ARTIFICIAL NEURAL NETWORK

Artificial Neural Networks, also known as “Artificial neural nets”, “neural nets”, or ANN for short, are a computational tool modeled on the interconnection of the neuron in the nervous systems of the human brain and that of other organisms. Biological Neural Nets (BNN) are the naturally occurring equivalent of the ANN. Both BNN and ANN are network systems constructed from atomic components known as “neurons”. Artificial neural networks are very different from biological networks, although many of the concepts and characteristics of biological systems are faithfully reproduced in the artificial systems. Artificial neural nets are a type of non-linear processing system that is ideally suited for a wide range of tasks, especially tasks where there is no existing algorithm for task completion. ANN can be trained to solve certain problems using a teaching method and sample data. In this way, identically constructed ANN can be used to perform different tasks depending on the training received. With proper training, ANN are capable of generalization, the ability to recognize similarities among different input patterns, especially patterns that have been corrupted by noise.

ANNs have been found to be effective systems for learning discriminates for patterns from a body of examples⁵. Activation signals of nodes in one layer are transmitted to the next layer through links which either attenuate or amplify the signal. ANNs are trained to emulate a function by presenting it with a representative set of input/output functional patterns. The back propagation training technique adjusts the weights in all connecting links and thresholds in the nodes so that the difference between the actual output and target output are minimized for all given training patterns¹.

In designing and training an ANN to emulate a function, the only fixed parameters are the number of inputs and outputs to the ANN, which are based on the input/output variables of the function. It is also widely accepted that maximum of two hidden layers are sufficient to learn any arbitrary nonlinearity⁴. However, the number of hidden neurons and the values of learning

parameters, which are equally critical for satisfactory learning, are not supported by such well established selection criteria. The choice is usually based on experience. The ultimate objective is to find a combination of parameters which gives a total error of required tolerance a reasonable number of training sweeps

The network consists of several "layers" of neurons, an input layer, hidden layers, and output layers. Input layers take the input and distribute it to the hidden layers (so-called hidden because the user cannot see the inputs or outputs for those layers). These hidden layers do all the necessary computation and output the results to the output layer, which (surprisingly) outputs the data to the user.

V. ARTIFICIAL NEURAL NETWORKS AND ITS SIMULATION RESULTS

At the beginning the speed is zero, and at 0.012 sec the speed reference increases to 700 RPM, at 0.1 sec a load of 0.1 NM is added, and finally at 0.2 sec the speed reference is increased to 900 RPM. Figure 3 shows the used simulation model in Simulink for the ANN speed controller.

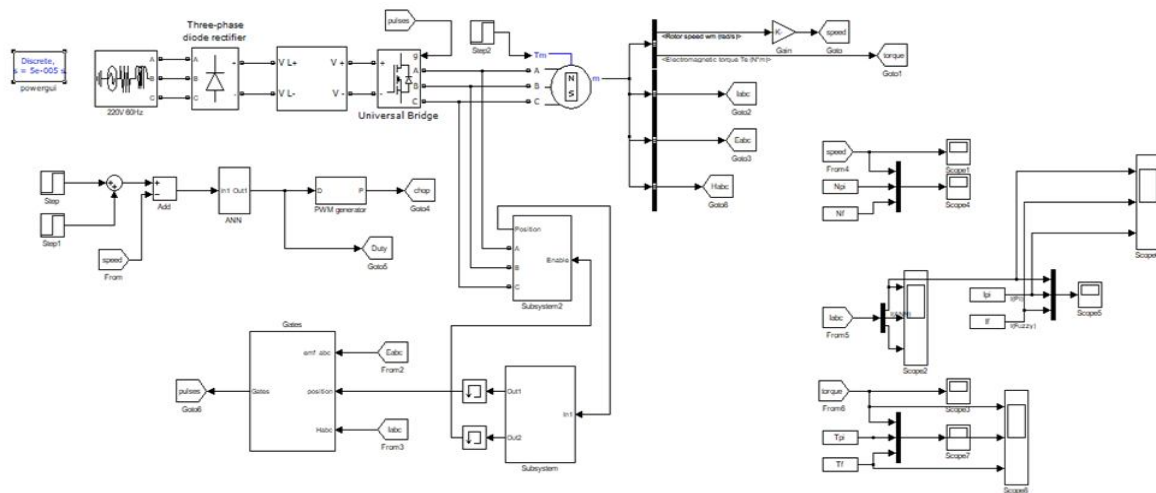

Fig.3 ANN Simulink Model

In figure 4, the speed response is shown, the rise time at the first step is 0.001 sec, and there is no overshoot, the settling time is about 0.01 sec.

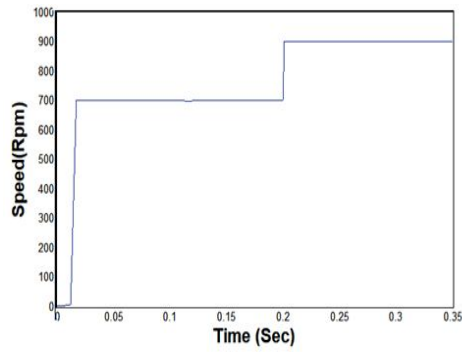

Fig.4 Speed response using ANN

For the second step (from 700 to 900 RPM), the rise time is 0.1 sec, and there is no overshoot, the settling time is about 0.201 sec. From figure 5, where the torque response is shown, the start-up torque is about 1.7N.M. At 0.2 sec, where the set point changed to 900 RPM, the torque rise up to 0.5N.M, and then returned to its steady value

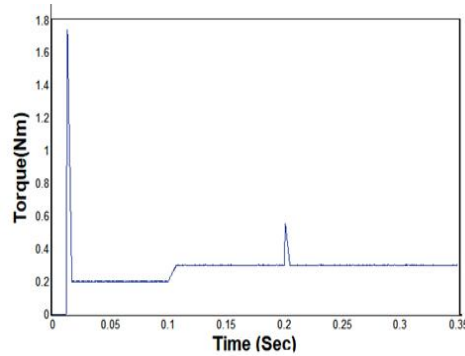

Fig.5 Torque response using ANN

In figure 6, where the BLDC motor phases currents are shown, the start-up current is about 0.25A. At 0.2 sec, where the set point changed to 900 RPM, the current rise up to 0.1 A, and then returned to its steady value

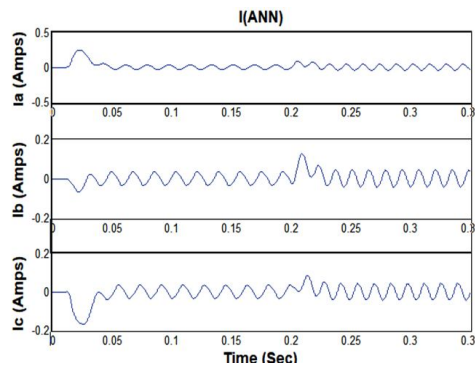

Fig.6 Motor Phase Currents using ANN

VI. COMPARATIVE STUDY

In³ PI speed controller and a fuzzy PI speed controller and ANN are used to control the speed of a BLDC motor with the same parameters of the one used in this paper..

In³, in case of PI controller, the settling time in the first step (from 0 to 700 RPM) is 0.04 sec. and in case of Fuzzy PI controller, the settling time is 0.03 sec. and in case of ANN it is 0.01Sec

The other performance parameters are extracted from the response speed curve of PI controller and the Fuzzy PI controller. From the table above, it is clear that in the first step (from 0 to 700 RPM), the ANN Controller performance is better.

And it is increased in stability without oscillations. The proposed PI controller has also a small settling time, which is 0.025 sec with almost no overshoot. For the second step (from 700 to 900 RPM), the performance of the proposed PI controller is almost the same as the compared one, and the speed is increased in stability too.

The start-up torque in the proposed PI controller is about 7.9N.M in the first step, but in³ the start-up torque is about 2.4N.M. The start-up current in the proposed PI controller is about 6A, while in³, the start-up current is 4 A. so in³, a smaller start-up current is achieved successfully, but with low start-up torque.

From the fuzzy PI controller, it is clear that in the first step (from 0 to 700 RPM), the proposed fuzzy PI Controller performance is better, as the proposed one has a very small rise time, which is 0.02 sec. and small settling time is 0.023sec with no overshoot.

For the second step (from 700 to 900 RPM), the performance of the proposed fuzzy PI controller is almost better than the compared one, as the rise time is about 0.004 sec, and settling time is 0.005 sec. The start-up torque in the proposed fuzzy PI controller is about 2.2 N.M in the first step, but in³ the start-up torque is about 0.9781 N.M The start-up current in the proposed fuzzy PI controller is about 2A, while in³, the start-up current is 1 A

From the Artificial Neural Networks, it is clear that in the first step (from 0 to 700 RPM), the ANN performance is better, as this one has a very small rise time, which is 0.001 sec. and small settling time is 0.01sec with no overshoot.

For the second step (from 700 to 900 RPM), the performance of ANN is almost better than the compared one, as the rise time is about 0.001 sec, and settling time is 0.002 sec. The start-up torque in the ANN is about 1.7 N.M in the first step, but in³ the start-up torque is about 0.5 N.M The start-up current in the proposed fuzzy PI controller is about 0.25A, while in³, the start-up current is 0.1 A.

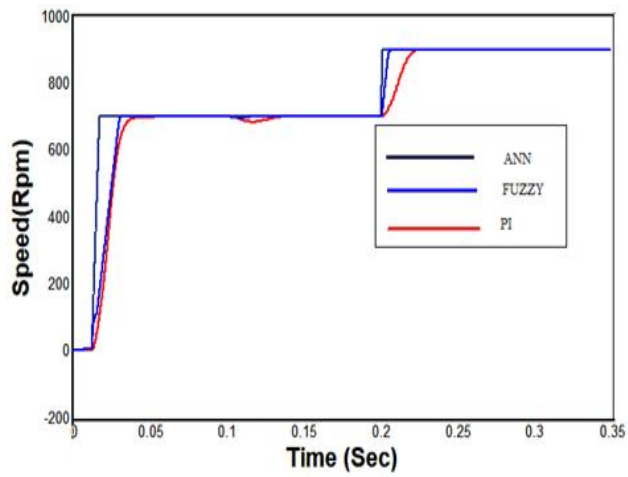

Fig.7 Speed response Of BLDC Motor

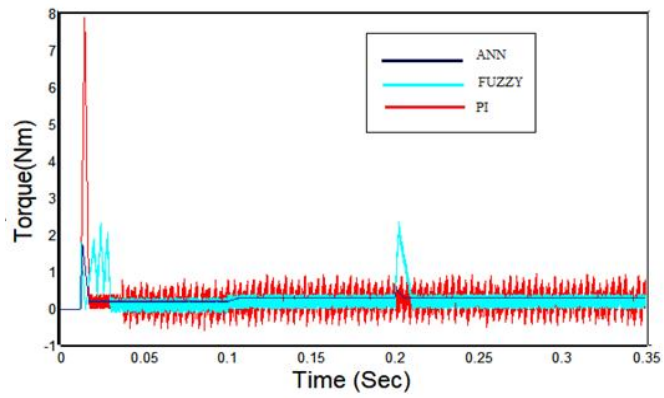

Fig.8. Torque response of BLDC Motor

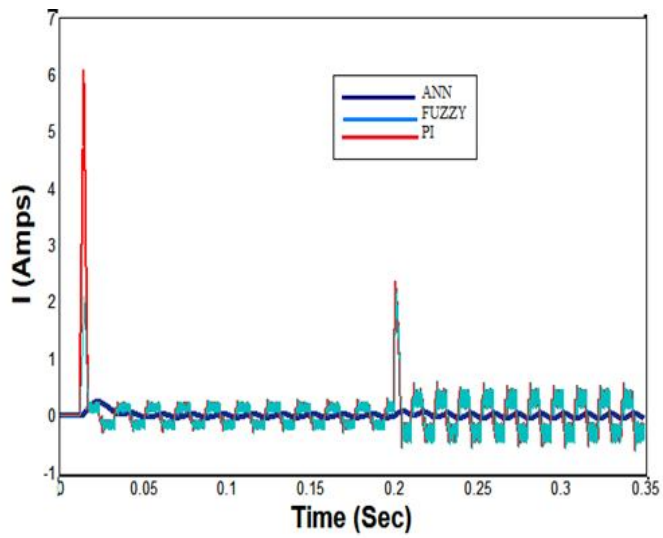

Fig.9. Phase Currents of BLDC Motor

Table 1: Comparative Study between PI Controller and Fuzzy PI Controller

Parameters	SPEED	PI	FUZZY	ANN
Rise Time	0-700	0.5	0.4	0.001
	700-900	0.3	0.2	0.1
Settling Time	0-700	0.04	0.03	0.01
	700-900	0.208	0.205	0.201
Start Up Current	0-700	6A	2A	0.25A
	700-900	2A	2A	0.1A
Start Up Torque	0-700	7.9NM	2.4NM	1.7NM
	700-900	2.2NM	2.1NM	0.5NM

CONCLUSION

Speed control of BLDC motor is presented in this paper, using PI controller, Fuzzy PI controller and artificial neural networks. In general the presented speed controller, ANN has better performance. A performance comparison of PI, fuzzy PI and ANN controller has been carried out by simulation. The results have shown that ANN controller is better than Fuzzy PI and conventional PI controller under variable operating conditions. A future work could be done to add current control function to the proposed speed controller, so the current can be kept within a certain range for a given speed, which will help in enhancing the motor startup current, reducing the motor current ripples, and enhancing the motor torque characteristics. Also by current control, the speed and torque variations can be reduced to minimum, by avoiding any sudden changes in the motor current value.

REFERENCE

1. Li Chunfeng, Yu Weibo, Tang Wusheng "Study on Rotor Position of Sensor less Brushless DC Motors Through Back Electromotive Force Detection" presented at E-Product E-Service and E-Entertainment (ICEEE) 2010 International Conference on, 7-9 Nov. 2010.
2. Xionghui, XueYanBo "The Design of Brushless DC Motor Back-EMF control" presented at Environmental Science and Information Application Technology (ESIAT) 2010 International Conference on, 17-18 July 2010.
3. Madhusudan Singh , Archana Garg "Performance Evaluation of BLDC Motor with Conventional PI and Fuzzy Speed Controller" presented at 10.1109/IICPE.2012.6450516 Conference: Power Electronics (IICPE), 2012 IEEE 5th India International Conference on

4. Padmaraja Yedamale "Brushless DC (BLDC) Motor Fundamentals" Microchip Technology Inc, AN885 application note, 11/11/2003. Available: http://ww1.microchip.com/downloads/en/AppNotes/0088_5a.pdf.
 5. Yu-Jhen Fu, Lu-Ting Huang, Ruey-Yue Lin, and ChengHu Chen "Reliable Starting Method for Sensor less Brushless DC Motor Drive" presented at Advanced Intelligent Mechatronics (AIM) 2012 IEEE/ASME International Conference on, 11-14 July 2012.
 6. Yen-Chuan Chang and Ying-Yu Tzou "A New Sensorless Starting Method for Brushless DC Motors without Reversing Rotation" presented at Power Electronics Specialists Conference, 17-21 June 2007. PESC 2007.IEEE.
 7. M. Baszynski, and S. Pirog "A novel speed measurement method for a high-speed BLDC motor based on the signals from the rotor position sensor" IEEE, 30 January 2013 10.1109/TII.2013.2243740.
 8. Sreekala.P, and Prof.Dr.A.Sivasubramanian "Speed Control Of Brushless Dc Motor With Pi And Fuzzy Logic Controller Using Resonant pole Inverter" presented at Innovative Smart Grid Technologies - India (ISGT India), 2011 IEEE PES, 1-3 Dec. 2011.
 9. R. Arulmozhiyal, and R.Kandiban "An Intelligent Speed Controller for Brushless DC Motor" presented at Industrial Electronics and Applications (ICIEA), 2012 7th IEEE Conference on, 18-20 July 2012.
 10. Tay, Teng-Tiow; IvenMareels; John B. Moore (1997). High performance control.Birkhäuser.p. 93.ISBN 0-8176-4004-5.
 11. Ogata, Katsuhiko (1987). Discrete-time control systems.Prentice-Hall.p. 344.ISBN 0-13-216102-8.
-