

International Journal of Scientific Research and Reviews

PAPR Reduction in OFDM Using Signal Scrambling Techniques

Patel Arpita

V.T Patel Department of Electronics and Communications, Chandubhai S Patel Institute of Technology, Charotar University of Science and Technology, Changa, Gujarat, India

ABSTRACT

With the advent of new high data rate wireless applications, demand of the spectrum is rapidly increasing. Orthogonal Frequency Division Multiplexing (OFDM) is promising candidate for flexible spectrum pooling in communication systems. Also it is an attractive method now a days in research community because of its robustness in the presence of severe multipath channel conditions with simple equalization, robustness against Inter-symbol Interference (ISI), multipath fading, in addition to its high spectral efficiency. OFDM is a good candidate for CR because of its flexibility and adaptability. Though OFDM has a many advantages, one of the major challenge in the OFDM systems is that it suffers from high peak to average power ratio (PAPR) as it has a huge number of subcarriers which leads to power inefficiency and signal distortion. A high PAPR also brings disadvantages like an increased complexity of the A/D and D/A converters and reduced efficiency of radio frequency (RF) power amplifier. A number of promising techniques like signal scrambling, signal distortion and coding techniques have been proposed and implemented to reduce PAPR of OFDM signal. In this paper, review of various PAPR reduction techniques based on signal scrambling techniques and their comparison to mitigate PAPR is discussed.

KEYWORDS: OFDM, PAPR, Subcarriers, signal scrambling

***Corresponding author**

Dr. Arpita Patel

Department of E&C,

Chandubhai S Patel Institute of Technology

Changa, Gujarat, India.

Email: arpitapatel.ec@charusat.ac.in, Mob No – 9428661555

INTRODUCTION

5G is the modern generation of cellular mobile communications. It succeeds the 4G (LTE-A, WiMax), 3G (UMTS, LTE) and 2G (GSM) systems. 5G performance goals for high data rate, energy saving, reduction in cost and good system capacity with huge device connectivity. It is expected that 5G will provide a complete and secure IP solution one can achieve “anytime, anywhere” in data and video with higher data rates than 4G.¹ To achieve high data rate 5G requires more progressive techniques. Orthogonal frequency division multiplexing (OFDM) have seems to very eye-catching technology in comparison to Interleave division multiple access scheme^{2,3} and it is adopted in LTE and now in 5G for its superior performance. Also, it has a high tolerance in fading and has a high spectral efficiency which makes it suitable for future wireless communication systems. Nevertheless, OFDM has many benefits, but high Peak-to-Average Power Ratio [PAPR] limits its performance² because OFDM subcarriers are large with high amplitude peaks. Since, high PAPR need complex circuitry at the transmitter side and due to inband distortion, BER and adjacent channel interference increases. In literature several solution have been discussed for reduction of PAPR which are divided in three groups as listed below:

Signal scrambling technique

Signal distortion technique

Coding technique

In this paper signal scrambling techniques are discussed and reviewed. The paper is organized as follows. Section II briefly presents the OFDM system model with basics. Section III describe the basics of PAPR and its reduction methods. Section IV conclude the paper.

2. OVERVIEW OF OFDM

OFDM works on the principle of Frequency Division Multiplexing (FDM)¹ but in controlled manner means it at higher spectral efficiency³. It is a multicarrier modulation technique that divides the available spectrum into subcarriers, with each subcarrier containing a low rate data stream. Subcarriers are coincided with each other and have a proper spacing between and having a pass band filter shape for orthogonality as shown in fig 1.

OFDM plays very key role in realizing Cognitive Radio (CR) concept for wireless communications due to its flexibility and adaptability³. OFDM uses maximum likelihood detection to reduce the complexity at receiver side. To prevent phase and frequency shift errors pilot subcarrier are used in OFDM. Since OFDM uses guard band in every OFDM symbol, inter-symbol interference (ISI) is reduced completely. Also it is robust to channel

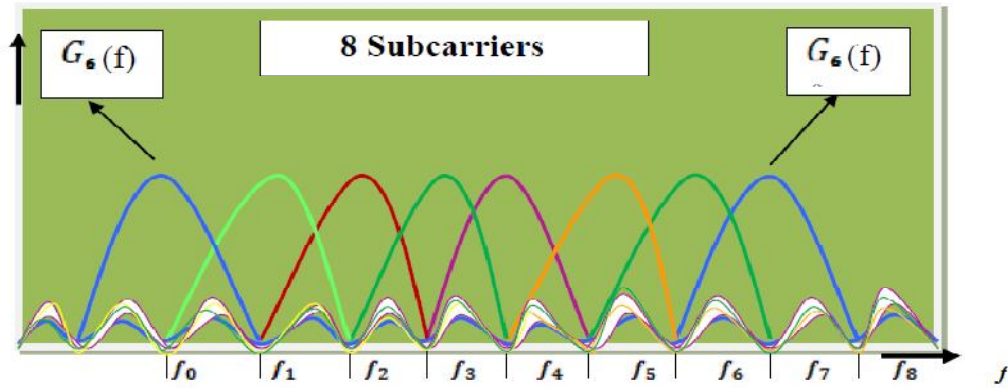

Figure 1: Subcarriers InOFDM

Fading. OFDM is used in many wireless real time applications such as in WLAN standards, in Video Broadcasting 3GPP-LTE etc.

OFDM model

Basic OFDM Model is shown in Figure 2. Input data symbols passed through channel encoder which are mapped onto BPSK/QPSK/QAM constellation. After that, serial data are converted to parallel form and now Inverse Fast Fourier Transform (IFFT) is used to generate orthogonal data. Using cyclic prefix (CP), signal is cyclically prolonged so that Inter Symbol Interference (ISI) can be removed from the former OFDM.

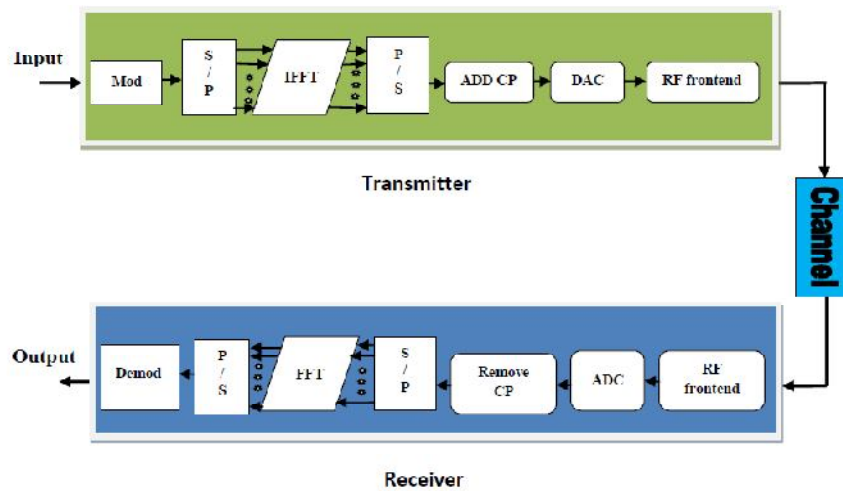

Figure 2: OFDM Model

This OFDM baseband digital signal is altered to analog signal by Digital to analog converter (DAC) and applied to RF frontend. OFDM consists of multiple carriers. Each carrier can be presented as a complex waveform like:

$$s_c(t) = A_c(t)e^{j[\omega_c t + \phi_c t]}$$

3. PAPR AND TECHNIQUES

PAPR means envelope fluctuation. Large peaks can result in nonlinear distortion. OFDM is a multicarrier system and the main problem of a multicarrier system is its large envelope fluctuation.⁴

$$PAPR \{x(t)\} = \frac{\max_{0 \leq t \leq T} \{|x(t)|^2\}}{E\{|x(t)|^2\}} \quad (1)$$

Where $\max\{|x(t)|^2\}$ is the peak signal power and $E\{|x(t)|^2\}$ is the average signal power.

Due to large subcarriers, high PAPR is introduced in OFDM systems. The complex envelope of the OFDM signal, over a T second interval is given by,

$$S(t) = A_c \sum_{n=0}^{N-1} w_n \phi_n(t), \quad 0 > t > T$$

Reduction of peak-to-average power ratio is always a concern for researchers. Various methods have been implemented to reduce PAPR. Broadly, PAPR reduction techniques are classified into 3 sections as follows,

- Signal scrambling technique
- Signal distortion technique
- Coding technique

3.1 Signal Scrambling Techniques

3.1.1 Block Coding

This is a very simple technique to diminish PAPR. It is used to reduce peak-to-mean envelope power ratio of a communication system⁵. The first step in block coding is to choose the code words which have a low peak power after coding. Encoded output is yielded by (n,k) block code and matrix G and a phase rotator vector. Large information is separated into different sub-blocks and then coded on chips to reduce PAPR.

3.1.2 Selective Level Mapping (SLM)

In this method, the input data is multiplied by a random series first, then the series which has a lesser PAPR is selected for the transmission as shown in figure 3. To get back the original data at the receiver side, the multiplied random series is sent as a side information.

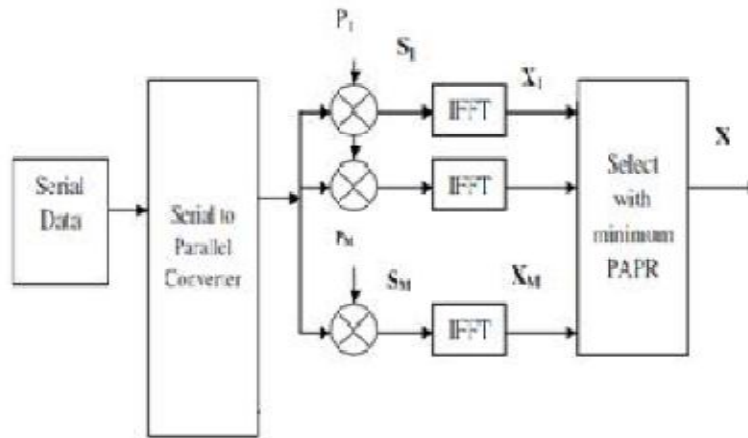

Figure 3: OFDM Transmitter Section With SLM Scheme

This method can significantly reduce the PAPR because the data blocks are independent for a single OFDM symbol. The likelihood of PAPR greater than the threshold is p . If we could able to search for the best phase factor then optimization is achieved. The plus point about this method is that, it is not eliminating the peaks and still can able to handle large quantity of subcarriers. The problem with this schemes is the burden of side information that is to be transmitted with subcarriers to retrieve the original data⁶.

3.1.3 Partial Transmit Sequences (PTS)

This technique is proposed in 1997. Here, the OFDM signal is first distributed into sub blocks and then phase shifting of sub blocks and then random vector multiplication is carried out in order to reduce PAPR as shown in figure 4. PTS is very effective and malleable. This is a modified version of SLM. Since there is no requirement to send side information for decoding, this scheme is very effective.

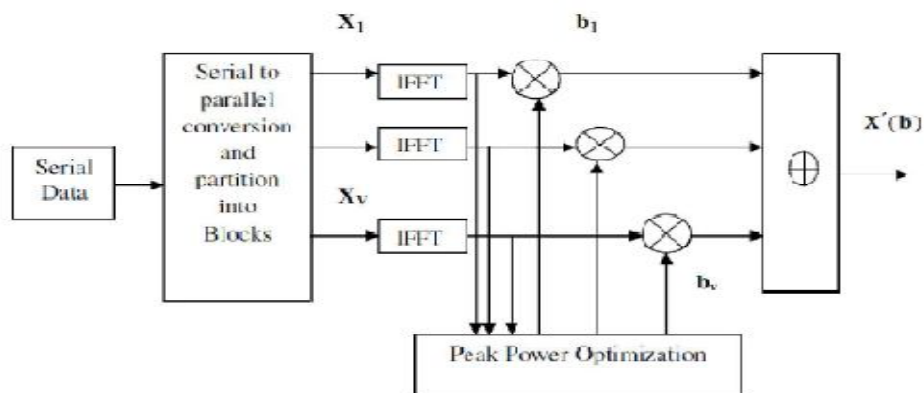

Figure 4: OFDM Transmitter Section With PTS Scheme

3.1.4 Interleaving Technique

This scheme has a less complexity than PTS technique yet it has a comparable performance. Interleaving doesn't give the surety of reduction on PAPR and under this situation, error correction codes with higher order are useful. The idea that highly correlated data structures have large PAPR can be reduced, if long correlation pattern is destroyed.

3.1.5 Tone Reservation (TR)

By reserving small amount of tones, large reduction in PAPR can be achieved by using simple method at transmitter without adding complexity at receiver side is the main key idea behind this scheme⁷. The factors that decides the amount of PAPR reduction are number of tones, complexity and position of the reserved tones. Less complexity and no need of side information are two main advantage of this scheme.

3.1.6 Tone Injection (TI)

This scheme is based on additive method to achieve reduction in PAPR of multicarrier signal without loss of data rate⁸. It uses equal constellation points to reduce PAPR. This method rises the constellation size and then original constellation is mapped in to many equivalent points. The name tone injection has been given to this method as it replaces the point in constellation for new points which is equivalent to injection of tone with exact phase and frequency in symbol. Side information for decoding and extra IFFT process make the system more complex⁹.

Comparisons of Various PAPR Reduction Techniques For Signal Scrambling:

Method	Parameters		
	Distortion less	Increase in power	Loss of data rate
Coding	Y	N	Y
PTS	Y	N	Y
SLM	Y	N	Y
Interleaving	Y	N	Y
TR	Y	Y	Y
TI	Y	Y	N

4. CONCLUSION

Though OFDM is very promise technique for future wireless technology it suffers from the drawback of high PAPR. Various scheme have been introduce to solve this problem. This paper review and compare various signal scrambling techniques in brief. One can choose proper method to get desirable PAPR.

REFERENCES

1. Sandeep Bhada, PankajGulhaneb, A.S.Hiwalec, "PAPR Reduction scheme For OFDM", Elsevier Ltd,2011,Procedia Technology 2012; 4: 109 – 113
2. Arpita Patel,JayminBhalani,M.Shukla,"Performance Evaluation of Invert Tree Based Interleaver with Receiver Diversity in Interleave Division Multiple Access", IJAER,2017; 12(22):12067-12074
3. Arpita Patel,JayminBhalani,M.Shukla," Structural Reduction in Front End Memory Requirement of Tree Based Interleaver Method Using the Concept of Invert Tree Based Interleaver in Multiuser Interleave Division Multiple Access Scheme", IJAER,2017;18(12): 7122-7131
4. P.Kalaivani,S.R. Balasubramanian,"PAPR Reduction Techniques for OFDM Systems", IJSR,2017,SPECIAL ISSUE NCSPCN 17
5. Mamta Bisht¹ and Alok Joshi² ," Various Techniques to Reduce PAPR in OFDM Systems: A Survey", IJSIP,2015; 8(11): 195-206
6. AbdulrahmanIkramSiddiq,"PAPR reduction in OFDM systems using peak insertion ", 2014 Elsevier, IEEE Communications Letters, 2016; 18,20(3): 446-449.
7. Jing gao¹, Jinkuan Wang², Xin Song², Bin Wang² ,"PAPR Reduction with Low Computational Complexity for OFDM Systems", Elsevier Ltd.Physics Procedia, 2012; 1401 – 1407
8. L. J. Cimini, " Analysis and Simulation of a Digital Mobile Channel Using Orthogonal Frequency Division Multiplexing,IEEETrans. Commun.,July 1985;33(7): 665-675,
9. J. Bingham, " Multicarrier modulation for data transmission: an idea whose time has come," IEEE Commun. Mag., May 1990; 28(5): 5-14,.
10. YasirRahmatallah, Seshadri Mohan," Peak-to-Average Power Ratio Reduction in OFDM Schemes: A Survey And Taxonomy, " IEEE Communications Surveys and Tutorials2013;15(4)