

International Journal of Scientific Research and Reviews

Performance of Series Filter in a Grid Connected Doubly Fed Induction Generator System

Keerthi V.^{1*}, Devi Rekha G.², Chathurya N.³, Prasad Venkatesh V.⁴

Dept. of EEE, Pragati Engineering College Surampalem, Andhra Pradesh India.
Email: vaskurikeerthi@gmail.com, Mob. 9553357337

ABSTRACT

The project deals with performance of the load when the grid connected DFIG wind turbines with series filter. The proposed technique will analyze the performance of grid when the Series Filter are placed at transmission line before the distribution of power to the load. It gives the strong grid scenario by reducing the reactive power consumption from grid side in the system. The commonly used load is non linear load. In this project performance analysis of a grid was carried on for distribution with and without Series Filter.

This project is to ensure the corresponding voltage, current and total harmonic distortion (THD) will be improved at a better level when compared with a grid which is not having any compensation device to improve the power quality of the system.

The main objective of this project is obtaining the better results in Voltage profile and also improving the power factor to get the proper electrical bill to the corresponding loads. The Stand alone operation of the DFIG system with integrated battery energy storage connected across the DC-link of ac/dc/ac converter is modelled. The connected load consisting of linear load and non-linear load is modelled. The Grid Side Converter is designed to control frequency and load bus voltage magnitude using droop control technique.

KEYWORDS: Series Filter, Doubly Fed Induction Generator (DFIG), Total Harmonic Distortion (THD).

***Corresponding Author:**

V. Keerthi

UG Scholar,

Electrical and Electronics Engineering, Pragati Engineering College,
Surampalem, Andhra Pradesh, India,

E Mail: vaskurikeerthi@gmail.com

INTRODUCTION

Now a days, nothing is possible without electricity. Without electricity modern society would cease to function. As the volume of power transmitted and distributed increases, so do the requirements for a high quality and reliable supply. Thus, reactive power control and voltage control in an electrical power is important for proper operation for electrical power equipment to prevent damage such as overheating of generators and motors , to reduce transmission losses¹ and to maintain the ability of the system.

Voltage control and reactive power management are the two aspects of a single activity that both supports reliability and facilitates commercial transactions across transmission networks. Thus reactive power is essential to maintain the voltage to deliver active power through the transmission lines.

DOUBLED FED INDUCTION GENERATOR:

The term Doubly Fed refers to the fact that the voltage on the stator is applied from the grid and the voltage on the rotor is induced by the power converter. This system allows a variable-speed operation over a large, but restricted, range. The converter compensates the difference between the mechanical and electrical frequencies by injecting a rotor current with a variable frequency . Hence, the operation and behaviour of the DFIG is governed by the power converter and its controllers.

The primary advantage of doubly-fed induction generators when used in wind turbines² is that they allow the amplitude and frequency of their on the wind turbine rotor. Because of this, doubly-fed induction generators can be directly connected to the ac power network and remain synchronized at all times with the ac power network. Other advantages include the ability to control the power factor (e.g., to maintain the power factor at unity), while keeping the power electronics devices in the wind turbine at a moderate size.

DYNAMIC MODELING AND CONTROL OF THE DFIG SYSTEM

The traditional wind turbine generator (WTG) systems³ employ squirrel-cage induction generators (SCIGs) to generate wind power. These WTGs have no speed control capability and cannot provide voltage or frequency support when connected to the power grid. During the past decade, the concept of a variable-speed wind turbine driving a doubly fed induction generator (DFIG) has received increasing attention because of its noticeable advantages over other WTG systems. Most existing wind farms and those in planning employ this type of WTGs. The DFIG wind turbines can provide decoupled active and reactive power control⁴ of the generator, more efficient energy production, improved power quality and improved dynamic performance. All these are

possible because of the control scheme that can be implemented in the back-to-back converters⁵ of the DFIG. Hence, the method of controlling this back-to-back converter plays a significant role in achieving better performance of the DFIG system.

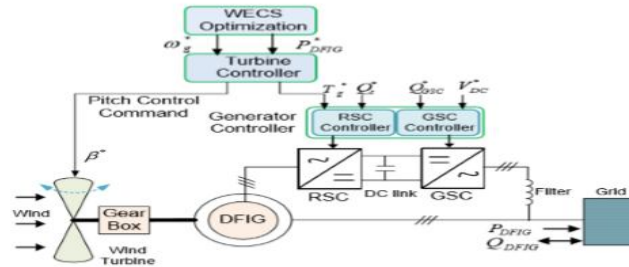

Fig.1: Controlling of Doubly fed induction generator for wind energy conversion system

SERIES FILTERS:

The output of the rectifier pulsating in nature, it consists of a desired DC component of voltage and unwanted ripple components. These ripple components are removed by placing filter circuit at the output of the rectifier.

Active power filters have several advantages over passive ones: compensation is automatic, there is no risk of resonances, unity power factor (or any other desired value) can be achieved permanently and without disturbing the electrical network, they can compensate for phase unbalance, and excellent performance can be achieved. They can also be combined with stated power. There are mainly two types of active power filters: the shunt active filter and the series active filter.

Active power filters are usually controlled by a microcontroller or a digital signal processor (DSP) with very good results. However, here an alternative for the controller is proposed, based on a personal computer with a general purpose multifunction data acquisition board included in the PCI bus. The major advantages of this approach are the relative low cost of the equipment, the high processing capabilities of the personal computer processor and its versatility, allowing many other tasks, such as data acquisition and logging, remote access and monitoring, integration with other systems, and many other possibilities. The methods applied to control the active filters are decisive in achieving the goals of compensation, in the determination of the filter power rate, and in their dynamic and steady state performance.

VOLTAGE REGULATION IN SERIES FILTER:

Voltage regulation can be maintained in the power system by supplying or absorbing the reactive power. Hence, the voltage regulation at a particular node in a power system is directly related to the reactive power capability of the devices directly connected to that node or present in

the vicinity of that node. Although, the DFIG-based wind turbines are able to control active and reactive power independently, the reactive power capability of those generators is limited as discussed. This problem is more severe in the case of DFIG wind turbines connected to weak power grids⁶ having under voltage condition as the reactive power capability gets even more degraded. Hence an additional local reactive power source is needed. Moreover, the power generation trend these days is shifting from the transmission network to the distribution grid, i.e. De-centralization of power generation. As a result, it is becoming more difficult to control the voltage in the entire transmission network from conventional power stations only. Hence grid companies are installing dedicated local voltage control equipments like capacitor banks, FACTS devices and are demanding distributed generation equipments to have their own reactive power capability as a result there cannot be any exemption for wind turbines. Furthermore, because of the increased penetration level of wind turbines in the power grid, utility companies are asking to fulfill certain criteria (grid codes) for the interconnection of wind turbines to the power grid.

SERIES FILTERS CONTROLLER:

The operation of the series filter controller is giving gate pulse to the series filter based on the comparison of voltages. By using multiplexer comparing the reference voltages with actual voltages giving the corresponding difference between the reference voltages and actual voltages. The comparison of inputs of 3 phases reference voltages with 3 phases actual voltages getting output is given to the multiplexer. The getting output is known as the Gate pulse. That gate pulse is given to the series filter. The operation of series is done based on the operation of switches. Here V_L is the actual voltages of simulink model and A,B,C are the reference voltages of the simulink model.

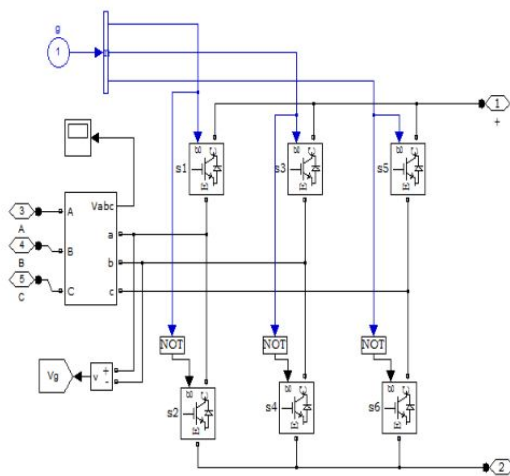
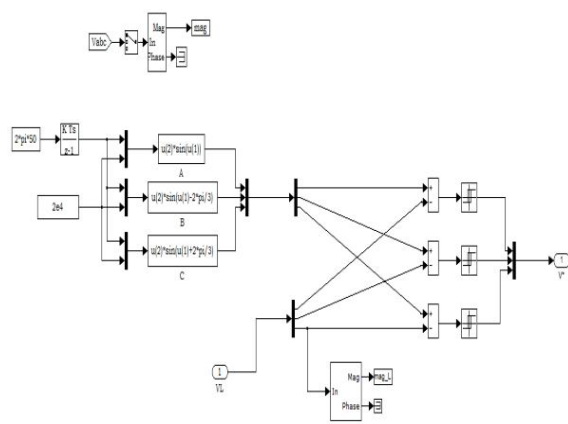

Fig (2) Switching operation of Series Filter Controller



Fig(3) series filter controller voltages

Formulae of series RLC filter :

Current equations

$$I_R=I_L=I_C=I(t)$$

$$I(t)=I_m \sin \omega t$$

Voltage equations

$$V_s^2 = V_R^2 + (V_L - V_C)^2 \quad \text{if } (V_L > V_C)$$

$$V_s^2 = V_R^2 + (V_C - V_L)^2 \quad \text{if } (V_C > V_L)$$

$$\text{Impedance, } Z = (R^2 + (X_L - X_C)^2)^{1/2}$$

$$\text{Power factor} = \cos \alpha = R/Z$$

$$\sin \alpha = (X_L - X_C)/Z$$

$$\tan \alpha = (X_L - X_C)/R$$

In this controller IGBTs are used for high power applications. Based on the operation of switches parameters controlling is achieved. The operation of series filter controller is when the gate pulse is given to the controller of three phases. When gate pulse voltage is comparing with rated voltage then battery it used to reduces the difference and gives the output of series filter is giving input to the load. In series filter thyristors operation based on the sequence (1,6),(2,4),(3,5). Here NOT gate is used because of reducing the short circuit currents⁷. If we observed swell then battery used absorb the voltage and sag is obtained then battery delivered the energy. Isolation transformer also used to connecting the series filter to the transmission line.

RESULT:

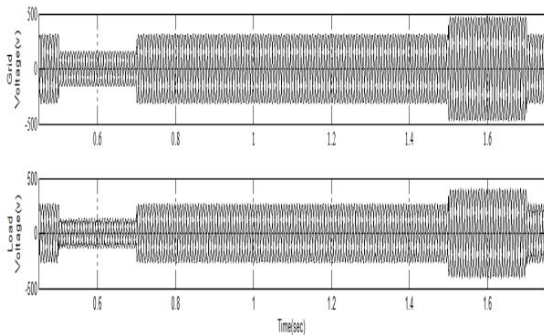

Fig(4) Grid and Load Voltages without Filter

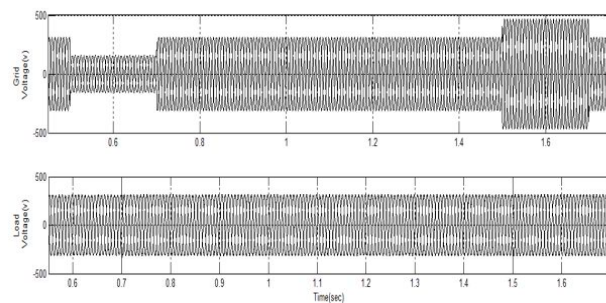

Fig(5) Grid and Load Voltages with Filter

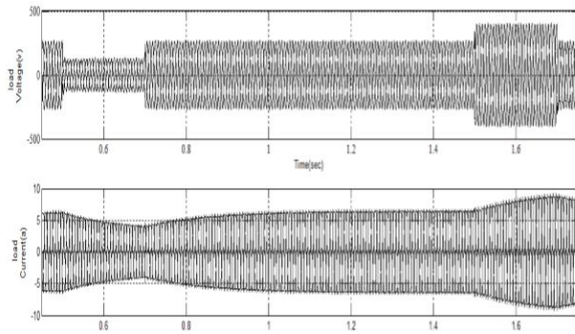

Fig(6) Load Voltage and Load Currents without Filter

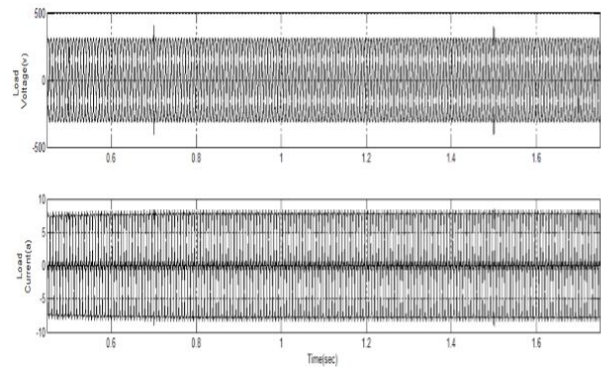

Fig(7) Load Voltage and Load Currents with Filter

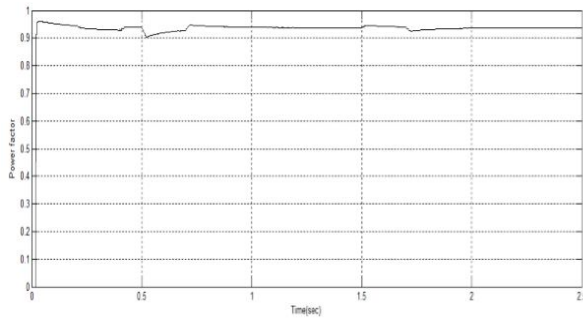

Fig(8) Power Factor without Series Filter

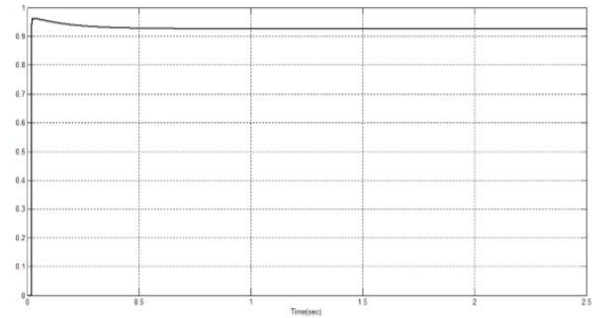

Fig(9) Power Factor with Series Filter

CONCLUSION

In this project, the performance is reliable by using series filter when compare with power system without series filter in meeting desired load conditions. The performance shows both steady state condition and transient state condition, also observes the weak grid scenario. The power factor has also been improved in the case of power transmission with series filter when compared with power factor without series filter.

REFERENCES

1. The World bank IBRD IDA, "Electric power transmission and distribution losses (% of output).[Accessed:05-May-2017]
Availablefrom:URL:<http://data.worldbank.org/indicator/EG.ELC.LOSS.ZS?end=2014&locations=SE&page=4&start=1960&view=chart>
2. S. Grunau and F. W. Fuchs, "Effect of Wind-Energy Power Injection into Weak Grids," in European Wind Energy Association 2012 Annuan Proceedings, 2012
3. Raymond W. Flumerfelt and Su Su Wang, "Wind turbines," in AccessScience, ©McGraw-Hill Companies, [Online].2009

4. B. Rabelo, W. Hofmann, J. da Silva, R. de Oliveira, and S. Silva, "Reactive power control design in doubly fed induction generators for wind turbines," *IEEE Trans. Industrial Electronics*, 2009; 56(10): 4154-4162
 5. J. Xu, S. Xie and T. Tang, "Evaluations of current control in weak grid case for grid connected," *Power Electronics, IET*, 2013; 6: 227–234
 6. A. Etxegarai, P. Eguia, E. Torres, A. Iturregi, and V. Valverde, "Review of grid connection requirements for generation assets in weak power grids," *Renewable and Sustainable Energy Reviews*, 2015; 41: 1501-1504
 7. T. Xia, M. Li, P. Zi, L. Tian, X. Qin, and N. An, "Modeling and simulation of Battery Energy Storage System (BESS) used in power system," *Proc. 5th IEEE Int. Conf. Electr. Util. Deregulation, Restruct. Power Technol. DRPT 2015*, 2016; 2120–2125
-