

International Journal of Scientific Research and Reviews

Particle Swarm Based Optimization Algorithm for Maximum Power Point Tracking in a Photovoltaic system

G. Mahesh¹ and M. Sreenivasulu²

¹PG scholar, Electrical and Electronics Engineering, Vasavi college of engineering, Hyderabad, Telangana, India.

²Assistant Professor, Electrical and Electronics Engineering, Vasavi college of engineering, Hyderabad, Telangana, India.

maheshgannoju26@gmail.com¹, m.srinivasulu@staff.vce.ac.in²

ABSTRACT

The Solar power mainly depends on the weather conditions. Many new algorithms have been projected to track the maximum power point (MPPT) of the solar system. In this paper utilization of a boost converter for control of photovoltaic power using Maximum Power Point Tracking (MPPT) control mechanism is presented. For the main aim of the project, we use boost converter along with the Maximum Power Point Tracking control mechanism. The MPPT is used to extract the maximum power from the photovoltaic cell and feed it to the load through the boost converter which steps up the voltage to required magnitude. The main aim is to track the maximum power point of the photovoltaic module so that the maximum power can be extracted from it. The algorithms utilized for MPPT are generalized algorithms and are easy to model or use as a code, and these are namely Perturb and Observe algorithm, Incremental Conductance algorithm, Fuzzy Logic controller algorithm, Particle Swarm based optimization algorithm. This paper presents these algorithms applied to Boost converter. From the MATLAB simulation results, it can be seen that the Particle Swarm based optimization algorithm offers better efficiency than the other methods.

KEYWORDS: MPPT, Particle Swarm based optimization algorithm.

***Corresponding author**

G. Mahesh

PG scholar, Electrical and Electronics Engineering,

Vasavi college of engineering, Hyderabad, Telangana, India.

E Mail ID - maheshgannoju26@gmail.com

INTRODUCTION

Solar energy is becoming much popular in various applications associating to heat, light, and electricity. It is especially attractive due to its abundance, renewability, cleanliness and the environmentally-friendly nature. One of the significant technologies of solar energy is photovoltaic (PV) technology which changes irradiation directly to electricity with the PV effect. However, it can be understood that the solar PV panels have some disadvantages such as low conversion efficiency (9% to 17%) and the effects of various weather conditions. V-I characteristic of a solar cell is non-linear, and it varies with irradiation and temperature¹. Generally, there is a single point on the V-I or V-P curve called Maximum Power Point (MPP). That means that a solar PV panel will operate with maximum efficiency and produces maximum output power. The Maximum Power Point is known on a V-I or V-P curve, and it can be located with the help of search algorithms such as Perturbation and Observation (P&O) algorithms^{2,3,4,5,6,7}, the Incremental Conductance (InC) algorithm^{8,9}, the Fuzzy Logic (FL) algorithm^{10,11}, and Particle Swarm Optimization (PSO) algorithm^{12,13}. These algorithms have many advantages and disadvantages involving simplicity, convergence speed, extra-hardware, and cost. This paper presents Particle Swarm Optimization algorithm for tracking an MPP on V-I characteristic of the solar PV panel. Based on the MPPT, the solar PV panel is always guaranteed to work in an adaptive and optimal condition. A Control strategy for a solar PV panel based on the MPP tracker (MPPT) with the Particle Swarm Optimization algorithm is presented. The simulation results then follow to confirm the effectiveness of the PSO algorithm.

PV CELL

Solar cells (as the name implies) are intended to convert (at least a portion of) available light into the electrical energy. They do this conversion without the use of chemical reactions and moving parts. The electronic arrangement of a solar cell can be inferred by building a model which is electrically equal and is based on discrete ideal electrical components whose performance is well-known. An ideal solar cell is modeled by a current source in parallel with a diode. As in practice, no solar cell is ideal, so we add a shunt resistance and a series resistance component to the model.

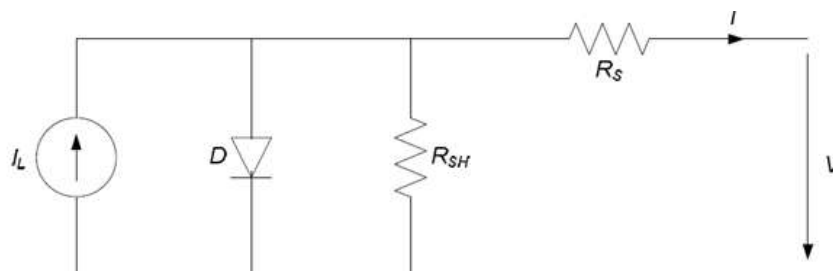

Fig 1. Equivalent circuit of a solar cell

From equivalent circuit diagram, it is evident that the electric current produced by the solar cell is equal to that produced by the electric current source, minus that of which flows through a diode, minus that which flows through a shunt resistor.

$$I = I_L - I_D - I_{SH} \tag{1}$$

Where

- I = output current
- I_L = photogenerated current
- I_D = diode current
- I_{SH} = shunt current

The electric current through these elements is governed by a voltage across them

$$V_j = V + IR_S \tag{2}$$

- V_j = voltage across both diode and resistor
- V = voltage across the output terminals
- I = output current
- R_S =series resistance

By the Shockley diode equation, the current diverted through the diode is:

$$I_D = I_0 \left\{ \exp \left[\frac{V_j}{nV_T} \right] - 1 \right\} \tag{3}$$

- I_0 = reverse saturation current
- n = Diode ideality factor (1 for ideal diode)
- k =Boltzmann's Constant
- T = Absolute Temperature
- $V_T = \frac{kT}{q}$ thermal voltage at 25° C, $V_T \approx 0.0259$

By Ohm's law, the current diverted through the shunt resistor is:

$$I_{SH} = \frac{V_j}{R_{SH}} \tag{4}$$

- R_{SH} = shunt resistance

Substituting these into the first equation, that produces a characteristic equation

$$I = I_L - I_0 \left\{ \exp \left[\frac{V + IR_S}{nV_T} \right] - 1 \right\} - \frac{V + IR_S}{R_{SH}} \quad (5)$$

MAXIMUM POWER POINT TRACKING

Maximum power point tracking(MPPT) is a technique used commonly with wind turbines and photovoltaic (PV) solar systems to maximize the power extraction under various conditions. Although solar power is mainly related to this MPPT, the principle generally applies to the sources with variable power. The various algorithms are reviewed followed by a description of the Particle Swarm Optimization algorithm.

P&O algorithm

The Perturb&Observe algorithm is also known as "hill-climbing", but both refer to the same algorithm depending on how it is implemented. Hill-climbing involves a perturbation on a duty cycle of the power converter and P&O the perturbation in the operating voltage of a DC link between the PV array and the power converter. In case of the Hill-climbing, perturbing the duty cycle of the power converter implies modifying the voltage of the DC link between the PV array and the power converter, so both names refer to the same technique.

The Perturb & Observe algorithm states that when an operating voltage of the PV panel is perturbed by a small increment if resulting change in power P is positive, then we are going in the direction of MPP and we keep on perturbing in the same direction. If P is negative, we are going away from the direction of MPP and the sign of perturbation supplied has to be changed. The flowchart for the P&O algorithm is shown in Figure 2.

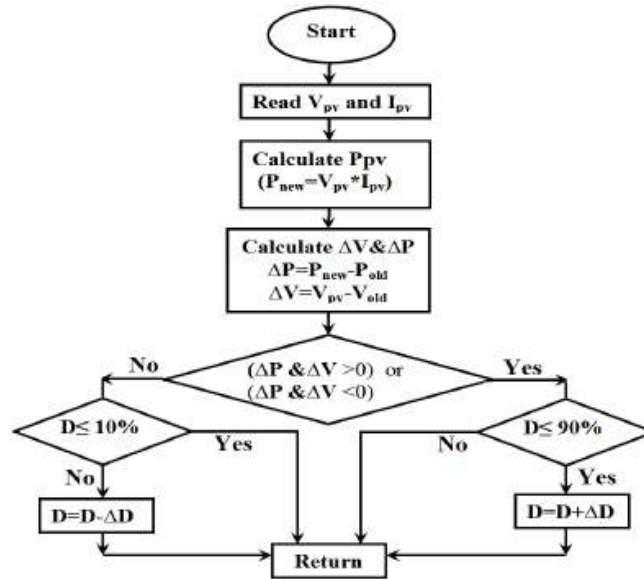

Fig 2:Flowchart of P & O algorithm

Incremental conductance (InC) Algorithm

The principle of the Incremental algorithm is that the derivative of the power concerning the voltage or current becomes zero at the Maximum Power Point, the power increases with the voltage in the left side of the Maximum Power Point and the power decreases with the voltage in the right side of the Maximum Power Point. This description can be written in the following simple equations:

$$P = VI \tag{6}$$

$$\left(\frac{dP}{dV}\right)_{MPP} = \frac{d(VI)}{dV} \tag{7}$$

$$0 = I + V \frac{dI}{dV_{MPP}} \tag{8}$$

$$\frac{dI}{dV_{MPP}} = \frac{-I}{V} \tag{9}$$

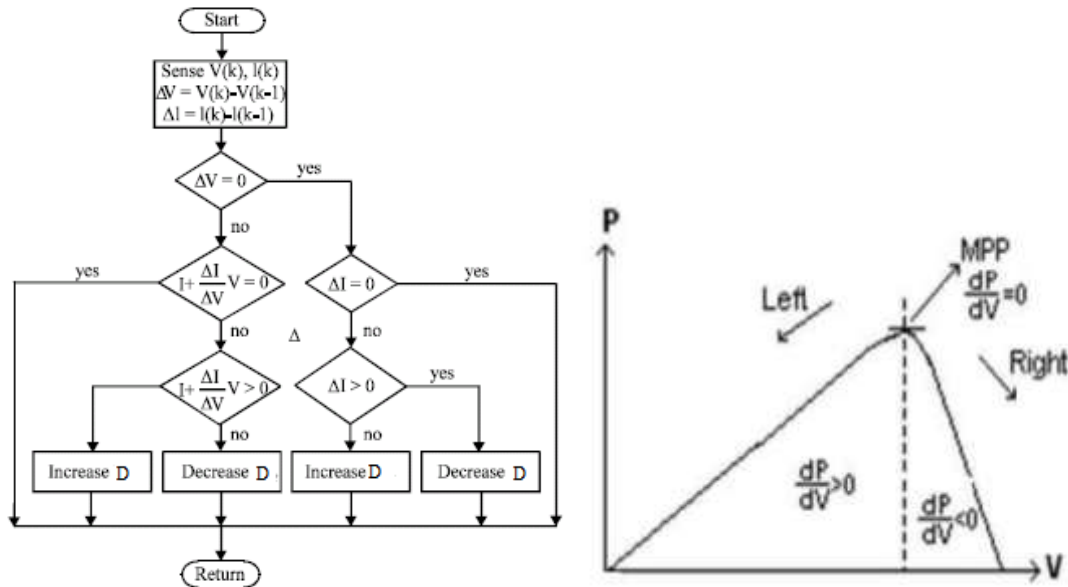

Fig 3: Flowchart and description of Incremental Conductance algorithm

$\frac{dP}{dV} = 0$ At MPP

$\frac{dP}{dV} < 0$ Right of MPP

$\frac{dP}{dV} > 0$ Left of MPP

Therefore, the voltage of the Photovoltaic panels can be adjusted relative to the voltage corresponding to MPP by measuring the incremental conductance, di/dv and the instantaneous conductance, I/V . It can be realized that the Incremental conductance algorithm overcomes the oscillation about the MPP when it is reached. When $di/dv = -I/V$ is satisfied, this means that the MPP is reached and the operating point remains. Otherwise, the operating point must be adjusted, which can be determined using the relationship between di/dv and $-I/V$.

i. *Fuzzification*: In this stage, the crisp input variables are transformed into linguistic variables based on the MFs. In this work, the fuzzy control MPPT method has two input variables, namely error (E) and change in error(CE), and one output variable, change in duty cycle(ΔD). There are five different fuzzy levels are used for inputs and output variables [NB (negative big), NS (negative small), ZE (zero), PS (positive small), and PB (positive big)]. Therefore, the proposed FLC will be controlled by 25 different rules. These fuzzy rules are included in Table 1 as shown below.

Table 1: Rule base

E \ CE	CE	NB	NS	ZE	PS	PB
NB		ZE	ZE	NB	NB	NB
NS		ZE	ZE	NS	NS	NS
ZE		NS	ZE	ZE	ZE	PS
PS		PS	PS	PS	ZE	ZE
PB		PB	PB	PB	ZE	ZE

The two input variables E and CE , at a sampling instant t are given by:

$$E(K) = (P(K) - P(K-1)) / (V(K) - V(K-1)) \tag{10}$$

$$CE(K) = E(K) - E(K-1) \tag{11}$$

where $P(k)$ and $V(k)$ are the power and voltages of the solar system, respectively. Based on these two inputs, FLC determines the next operating point depending on the used membership functions and a rule table. The input $E(k)$ provides information about how far the current operating point is from that of the MPP, while the input $CE(k)$ expresses how fast the operating points is moving towards or far from the MPP. If the value of $E(k)$ is greater than zero the controller changes the duty cycle to increase the voltage until the power is maximum or the value $(\Delta P / \Delta V) = 0$, if this value less than zero the controller adjusts the duty cycle to reduce the voltage until the power is maximum.

ii. Inference engine: Once E and CE are evaluated, they are transformed into linguistic variables with five membership functions. After the classification of the values, a decision is made based on a rule shown in Table 1 (This table based on the DC-DC converter). These rules are stated as (IF-THEN statements) and

the syntax is as follows:

IF (E is PB) AND (CE is NB) THEN (ΔD is PB).

iii. Defuzzification: The output of FLC is a fuzzy subset. As the real systems need a crisp value of Control, defuzzification is needed. Defuzzifier is employed to transform the fuzzy linguistic sets back into actual mathematical equivalents magnitude. This produces an analog signal that will

control the DC-DC converter to the MPP. The defuzzification is carried out by using the centroid method (weighted average method) which is expressed as:

$$\Delta D = \frac{\sum_i^n \mu(D_i) D_i}{\sum_i^n \mu(D_i)} \quad (12)$$

where ΔD is the crisp value output value, D_i is the center of maximum-minimum composition at the output MFs, $\mu(D_i)$ is the maximum of the i^{th} membership function, D_i is the i^{th} input value.

Particle swarm optimization(PSO):

Particle swarm optimization (PSO) algorithm refers to an optimization approach for the public interest in society. It gained inspiration from the flocking behavior of birds or fish that individuals communicate in such a manner that the entire population migrates toward the same target in the same direction.

Overview of PSO algorithm:

- 1) N particles are initialized randomly in a search space.
- 2) Out of N particles, the i^{th} particle is chosen and its fitness value (here we consider power of each particle) is evaluated based on the objective function.
- 3) If individual fitness value of this solution outperforms its foregoing one, then its $P_{best,i}$ value is updated.
- 4) Every particle is evaluated based on its present and foregoing individual fitness value.
- 5) P_{best} values of all the individually evaluated particles are then considered and a global best value G_{best} is evaluated from them using equation (15).
- 6) For every particle, its position and velocity are updated using the equations (13) & (14) respectively.
- 7) Iterations of this process are continued until a certain convergence criterion is reached.

Standard PSO equations are given as

$$V_i(K+1)=wV_i(K)+C_1rand_1 (P_{best,i} - X_i(K))+C_2rand_2 (G_{best} - X_i(K)) \quad (13)$$

$$X_i(K+1)=X_i(K)+V_i(K+1) \quad (14)$$

$$G_{best}=\text{MAX} \{P_{best,i}|i=1,2,\dots,N\} \quad (15)$$

Where,

$w=0.001$ = inertia weight

$C1 = 2$ = cognitive acceleration coefficient

$C2 = 2$ = social acceleration coefficient

$rand1, rand2$ = random numbers between (0,1) distributed uniformly

$P_{best,i}$ = individual best fitness value(power) of i th particle

G_{best} = global best fitness value(power) of all particles

K = present iteration number

$V_i(K)$ = i th particle velocity in existing looping cycle

$V_i(K + 1)$ = i th particle velocity in next looping cycle

$X_i(K)$ = i th particle position in existing looping cycle

$X_i(K + 1)$ = i th particle position in next looping cycle.

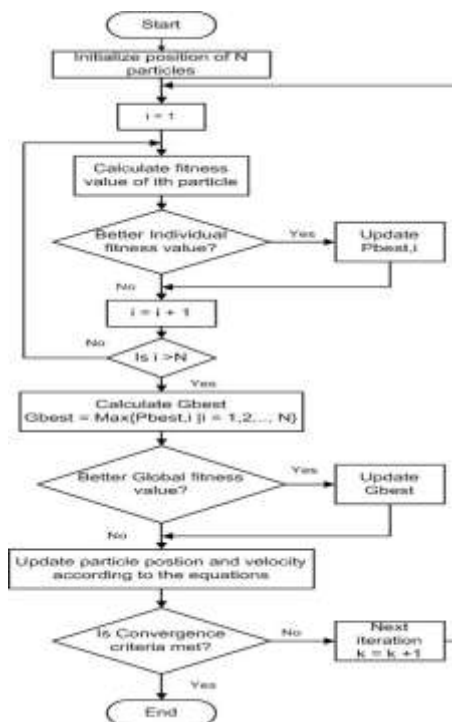

Fig 4:PSO flowchart

SIMULATION AND RESULTS

Simulations are performed using MATLAB/SIMULINK software for tracking MPPs of the solar PV array with panels, 2 in series and 4 in parallel whose specifications and parameters are in Table 2. The solar PV panel provides a maximum output power at a MPP with V_{MPP} and I_{MPP} . The MPP is defined at the standard test condition (STC) of the irradiation, 1 kW/m^2 and module temperature, 25°C but this condition does not exist most of the time. The following simulations are implemented to confirm the effectiveness.

Table 2: Specifications of Solar cell

Maximum power, P_{max} (W)	175
Voltage at P_{max} , V_{MPP} (V)	17.64
Current at P_{max} , I_{MPP} (A)	1.25
Short-circuit current, I_{sc} (A)	1.34
Open-circuit voltage, V_{oc} (V)	21.99

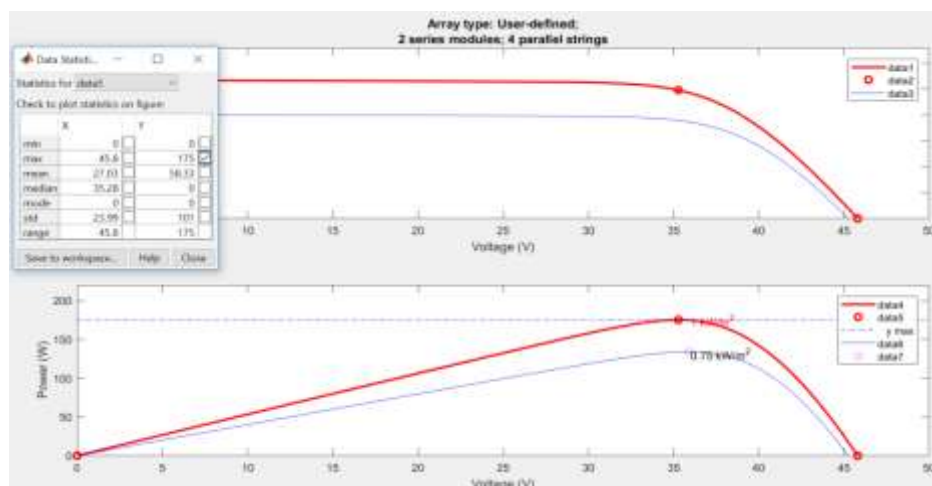

Fig 5: MPPs of the solar PV panel at Irradiance= 1000w/m^2 and temperature= 25°C .

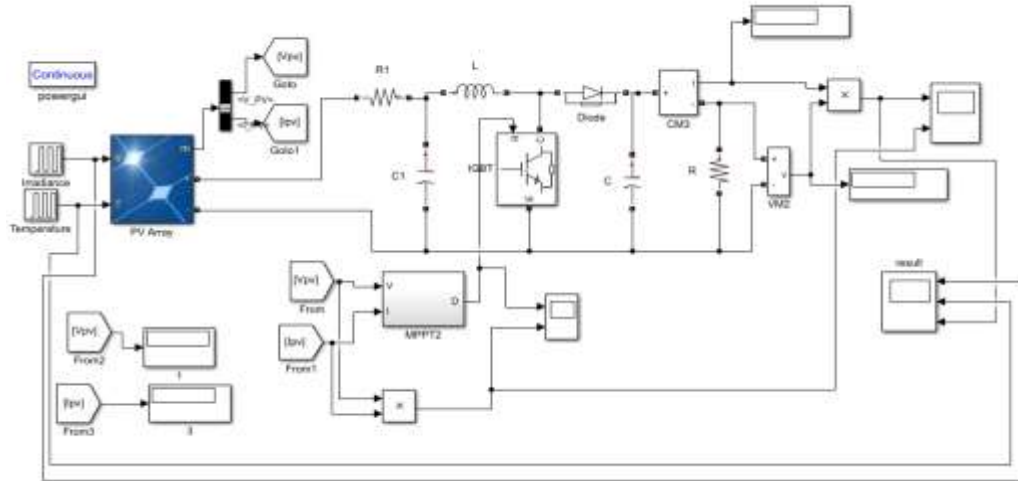

Fig 6: MATLAB simulation circuit of PV system

P&O result:

With various irradiances and temperatures, the output power for P & O algorithm are as follows.

For irradiance=1000w/m², temperature=25 deg C, the output power fluctuates between 140 watts and 175 watts.

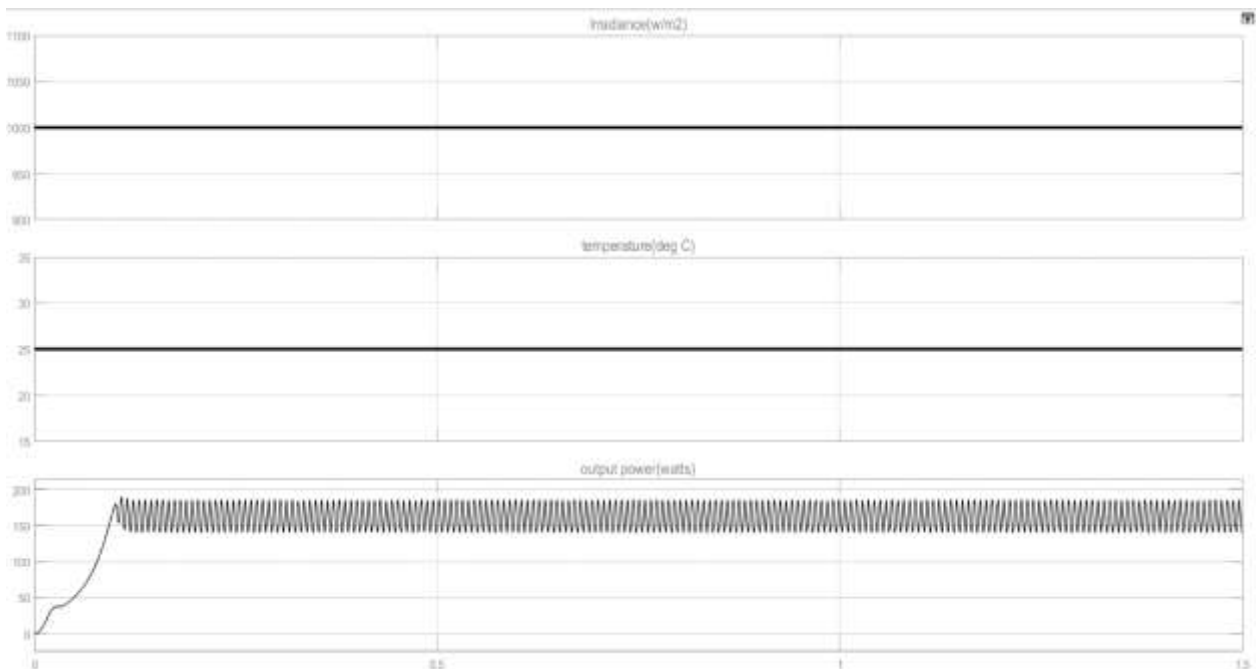

Fig 7: P & O algorithm Output Power with constant irradiance and constant temperature

Incremental Conductance result:

With various irradiances and temperatures, the output power for Incremental Conductance algorithm are as follows.

For irradiance=1000w/m², temperature=25 deg C, the output power fluctuates between 155 watts and 180 watts.

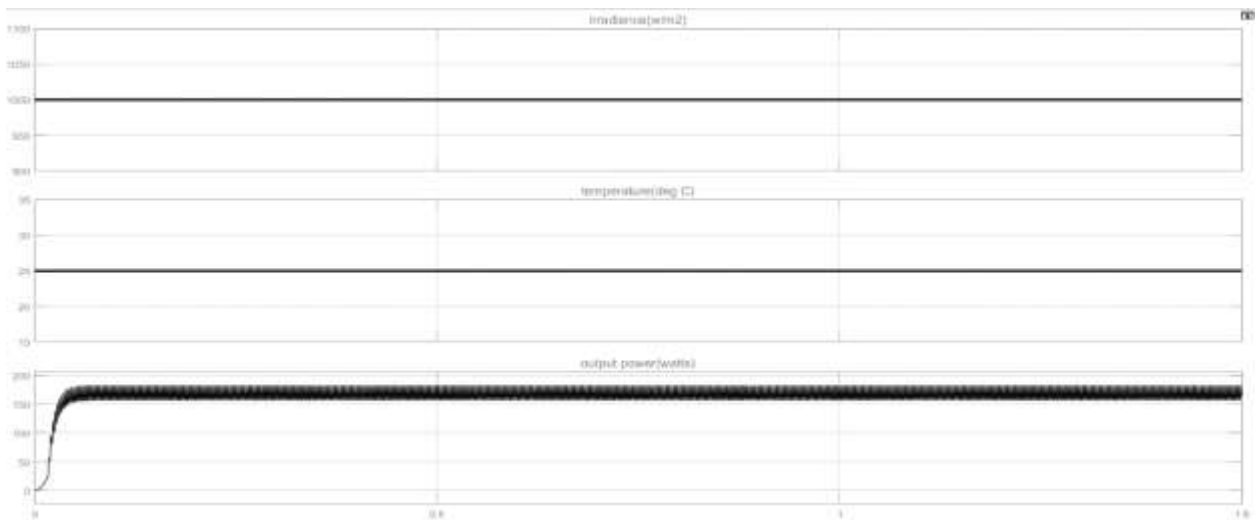

Fig 8: InC algorithm Output Power with constant irradiance and constant temperature

Fuzzy logic result:

With various irradiance and temperatures, the output power for Fuzzy Logic algorithm are as follows.

For irradiance=1000w/m², temperature=25 deg C, the output power is 164 watts.

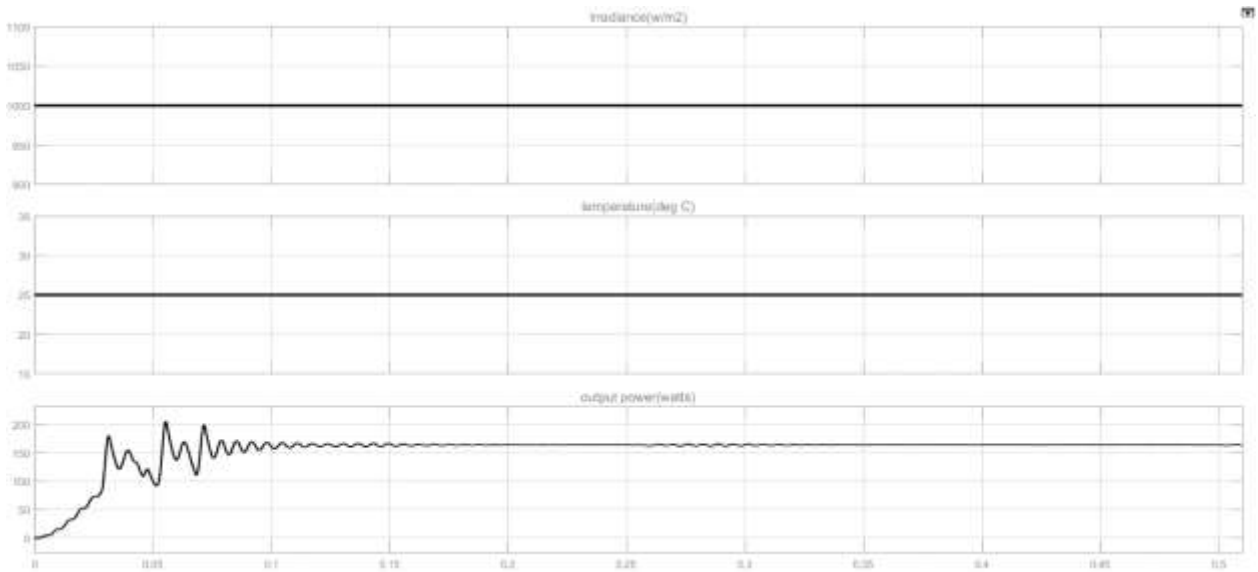

Fig 9: Fuzzy logic Controller algorithm Output Power with constant irradiance and constant temperature

PSO result:

With various irradiance and temperatures, the output power for PSO algorithm are as follows. For irradiance =1000w/m², temperature = 25 deg C, the output power is 168 watts.

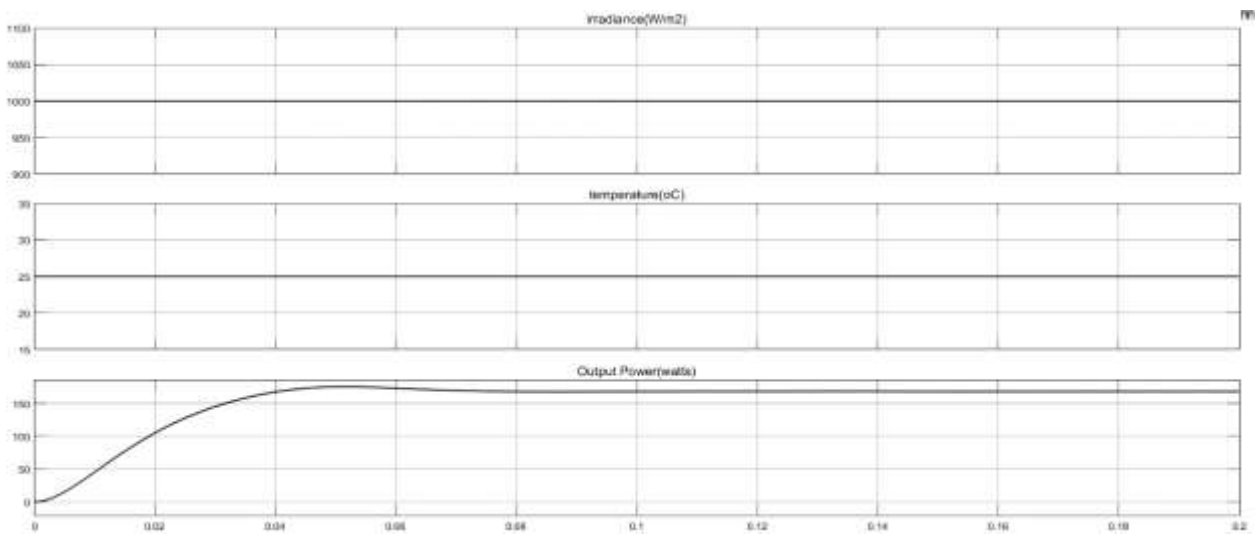

Fig 10: PSO algorithm Output Power with constant irradiance and constant temperature

Controller efficiency = $\frac{\text{output power of PV cell}}{\text{maximum power of cell}}$; comparison of various algorithms at irradiance=1000w/m² and temperature=25°C.

Table 3: Comparison of Controller efficiency

Algorithm	P & O	Incremental conductance	Fuzzy logic	PSO
Theoretical power	175	175	175	175
Practical power	158	160	164	168
Controller efficiency	90.28	91.43	93.71	96

CONCLUSION

MPPT control strategy for a PV system ensure that the solar PV panel can harness the maximum solar energy following the sun's trajectory from dawn until dusk and is always operated at the MPPs with the MPPT algorithms. This paper presents various MPPT algorithms. They are, P & O algorithm, Incremental conductance algorithm and Fuzzy logic algorithm and Particle Swarm optimization algorithm. PSO algorithm gives better results compared to the previous three algorithms with an approximation which reduces the oscillations around MPP as well as increase the efficiency of power extraction from PV system. This improvement overcomes the existing drawbacks of the previous algorithms. The MATLAB simulation results confirm the effectiveness of this control strategy in the PV system through the comparisons with other strategies.

REFERENCES

1. R. Faranda and S. Leva, "Energy comparison of MPPT techniques for PV systems," *Trans. Power System*, 2008; 3(6): 446-455.
2. R. Sridhar, S. Jeevananthan, N. T. Selvan and P. V. Sujith Chowdary, "Performance improvement of a photovoltaic array using MPPT P&O technique," *Int. Conf. Control and Comput. Technol.*, 2010;191-195,
3. N. M. Razali and N. A. Rahim, "DSP-based maximum peak power tracker using P&O algorithm," *IEEE First Conf. Clean Energy and Technology*, 2011; 34-39,.
4. L. Chun-Xia, L. Li-qun, "An improved perturbation and observation MPPT method of photovoltaic system," *4th IEEE Conf. Ind. Electron. and Appl.*, ICIEA 2009; 2966-2970.
5. Y. Jung, J. So, G. Yu and J. Choi, "Improved perturbation and observation method (IP&O) of MPPT control for photovoltaic power systems," *31st IEEE Photovoltaic Specialists Conference*, 2005;1788-1791.

6. X. Liu, L. A. C. Lopes, "An improved perturbation and observation maximum power point tracking algorithm for PV arrays," IEEE 35th Annual Power Electron. Specialists Conf., 2004; 2005-2010.
 7. D. C. Huynh, T. A. T. Nguyen, M. W. Dunnigan and M. A. Mueller, "Maximum power point tracking of solar photovoltaic panels using advanced perturbation and observation algorithm," IEEE Conf. Industrial Electronics and Applications 2013; 864-869.
 8. B. Liu, S. Duan, F. Liu and P. Xu, "Analysis and improvement of maximum power point tracking algorithm based on incremental conductance method for photovoltaic array," 7th Int. Conf. Power Electron. and Drive Syst., PEDS 2007; 637-641.
 9. W. Ping, D. Hui, D. Changyu and Q. Shengbiao, "An improved MPPT algorithm based on traditional incremental conductance method," 4th Int. Conf. Power Electron. Syst. and Appl, PESA2011; 1-4.
 10. S. J. Kang, J. S. Ko, J. S. Choi, M. G. Jang, J. H. Mun, J. G. Lee and D. H. Chung, "A novel MPPT control of photovoltaic system using FLC algorithm," 11th Int. Conf. Contr., Autom. and Syst., 2011; 434-439.
 11. V. Padmanabhan, V. Beena and M. Jayaraju, "Fuzzy logic based maximum power point tracker for a photovoltaic system," Int. Conf. Power, Signals, Contr. and Comput., EPSCICON 2012; 1-6.
 12. Md. A. Azam, S. A. A. Nahid, M. M. Alam and B. A. Plabon, "Microcontroller based high precision PSO algorithm for maximum solar power tracking," Conf. Electron. and Vision, 2012; 292-297.
 13. K. Ishaque, Z. Salam, M. Amjad and S. Mekhilef, "An improved particle swarm optimization (PSO)-based MPPT for PV with reduced steady-state oscillation," IEEE Trans. Power Electron., 2012; 3627-3638.
-