

International Journal of Scientific Research and Reviews

Analysis of Bicycle Frame Produced By Squeeze Cast Composite

**Subbaraya Mohan Kumar^{1*}, S Srinivas², M Ramachandra³,
K V Mahendra⁴ and J.V.Raghavendra⁵**

^{1*} Assistant Professor & Research Scholar, Jyothy Institute of Technology,
Bangalore -560062, India

^{2,3} Department of Mechanical Engineering, BMS College of Engineering, Bangalore -560019, India

⁴ Department of Mechanical Engineering, Amrutha Institute of Engineering and Management
Sciences

⁵ Assistant Professor, Jyothy Institute of Technology, Bangalore -560082, India

ABSTRACT

The use of aluminum alloys plays a vital role in automobile application as they possess excellent Mechanical and Physical properties. The drawback of aluminum alloys they exhibit weak corrosion resistance. To overcome this problem aluminum alloys are reinforced with Fly ash and SiC which are adequately known as Hybrid Composites. Metal Matrix composites (MMCs) which play a vital role in improving the stiffness, specific strength, wear, creep, and fatigue properties. The reinforcement mainly used to reduce the density and more excellent wear resistance and can be tailored for a suitable application. In the present research work Metal matrix composite MMC2 (5 % Fly ash 7% SiC), has been fabricated by using Squeeze cast technique subjected to mechanical properties. In this work, an effort has been made to evaluate the optimum cross-section for a bicycle frame using Finite Element Technique. For different cross-sections like Circular, Hollow tube, and T section the Maximum Deflection, and Maximum Bending stress has been evaluated. The present research work revealed that the T section is better compared to other cross-sections to withstand the load of 100 Kg.

KEYWORDS: Metal Matrix Composite, ANSYS, Bicycle Frame, Deflection, Bending Stress.

***Corresponding author**

Subbaraya MohanKumar

Department of Mechanical Engineering,

Jyothy Institute of Technology,

Bangalore -560082, India

Email: mohankumar.ts@jyothyit.ac.in,

MobNo-9916013878

1. INTRODUCTION

In today's scenario, Bicycles play a critical role in minimizing pollution and found to be the economical and cheapest mode of transport. Metal matrix composite (MMCs) are developed for lightweight materials in sectors like Aerospace and Structural applications. The application of MMCs has been brought down to more modest speeds at ground level. MMCs fabricated through Powder Metallurgy, Squeeze cast route has been limited to use in frames. This frame plays a vital role in the side characteristics of a bicycle, and it is the most obvious place for a designer to use as an exotic material. The first commercial bicycle to project the MMCs frame was released in 1991, with the number of manufacturers using these materials. The most important reason for this is the emergence of Mountain Bikes for off-road riding, which generated much interest in cycling by introducing new design configurations into the market. By the application of advanced materials such as MMCs frames are chosen at the top end of the market where they compete with the materials like Steel alloys, Aluminium alloys, Titanium, and Beryllium alloys.¹ Bicycles are mainly subjected to different types of loads at various locations around the frame. In the year 1968, the first published measurement of loads applied to a bicycle was done. By strain gauges mounted on the pedal and crank of a bicycle, ergometers were used to measure the pedaling loads.² Using cine film analysis, the loads on the bicycle frame were measured indirectly using strain gauges.³ By implementing the Finite Element model in the assessment of bicycle frame subjected to various load conditions using numerical simulation and simulate the behavior of a standard steel bicycle frame. The resulting stresses were analyzed for static, and fatigue strength, The Von mises stresses of 228 MPa was observed at the front wheel, 224 MPa at the down tube junction and 260 MPa near the welded joint at the top of the seat tube junction.⁴ By adopting the Parametric Finite element analysis of steel bicycle frames on the influence of tube selection on frame stiffness and range of existing frame, geometries were subjected to various in-plane and out plane conditions. The effect of tube profile properties on vertical compliance and lateral stiffness was evaluated and found that the most significant contributors of the performance measure are the down tube, right-hand seat stay and top tube with stiffness compliance ratios varying by 62%, 19%, and 11% respectively.⁵ By performing engineering evaluation of reactivity of racing bicycle wheels found that the wheel reacting index calculated for three rear wheels different for materials. Federico Giubilato & et al.⁶ performed engineering evaluation of reactivity of racing bicycle wheels, and they found that wheel reactivity index calculated for three rear wheels different for materials rim profile, spokes number and deposition

Perceived by the cyclist was developed. The height correlation coefficient of 0.93 was obtained by the engine Reactivity Index. The Reactivity perceived by the cyclists on the same wheels was validated by

the method for development. Joachim Vanwalleghem & et al.⁷ developed the multi-directional rating test method for bicycle stiffness for various parameters like applied load, boundary conditions, and frame deflection measurement. The test bench deflection before and after the reinforcement was measured at three locations and found that the reinforcing the test bench had led to frame stiffness with an increase of 25%. The result also showed an accuracy of less than 2% on the measured stiffness value. Anton Koellner & et al.⁸ conducted a Measurement and analysis system for bicycle field test studies adopted. Twenty four sensors were adopted for

Measuring strain, Four sensors for measuring acceleration, and a stand-alone data acquisition unit. The studies were conducted on a BMX bicycle with the optimization of the power supply, and the application to the bicycle possibly decreased the total mass of the system. The system was proved by its usage in race simulation on a BMX race track. Derek Covill & et al.⁹ simulated parametric analysis of a bicycle frame geometries using Finite Element Analysis. Smaller frames of (490 mm seat tube) were the most favorable in terms of both vertical compliance and lateral stiffness. The optimized value obtained showed that there was a considerable improvement over the existing frames with 13% increase in the vertical displacement and 15% decrease in the lateral displacement which compared with the best of the analyzed frames. Paolo & et al.¹⁰ carried out the structural design of a composite bicycle fork developed a numerical model to compare the stiffness, strength, and failure mode for two manufacturing solutions. The numerical model was validated by posterior linear stiffness comparison with the manufactured component and observed that the implementation of head tube prosecution inside the crown plays a vital role in terms of strength and stiffness. The FE analysis suggests that interlaminar bond failure as a predominant potential mode with the traditional design solution. The linear stiffness comparison represents a simple and effective approach for the validation of FE models in this class of products. Christopher J & et al.¹¹ Investigated structural responses on a BMX racing cycle conducted simultaneous acquisition of 28 measurements channels out of which 24 were used for strain measurements and 4 for acceleration measurements. Minimum stress of 190 MPa was generated within the bicycle frame Also, Accelerations from -25g to 43g and magnitudes of a strain of up to 2750 $\mu\epsilon$ are obtained. The area on the down tube and top tube close to the joint with the head tube was identified as the highly loaded region of the bicycle frame which coincided with the known failure locations of BMX bicycles. R. R. Chang & et al.¹² investigated the Design and Manufacturing of a Laminated Composite Bicycle Crank produced by compression molding technology. The materials used for two torque square prism are medium and high carbon steels after heat treatment with the reinforcement crank achieved a hardness from 45 to 54. With the turning speed of 100 rpm indicate that the crank without the inner reinforcement crank deformation angle 6.5° while the torque strength was 25.37 Kgf-m. With the inner reinforcement cranks for the

metallic square prism, the deformation angles range from 17 to 21° while the torque strengths varied between 32.63 and 36.82 Kgf-m. Alexandre Callens & et al.¹³ developed the Fatigue design of a welded bicycle frames using a multiracial criterion of a welded frame which is made up of thin-walled tubes inferred that the Dang Van multiaxial fatigue criterion is adapted for the calculation of multiaxial stress in critical areas of bicycle frames. The automatic meshing developed was proved to be accurate for an industrial application. Larry B Lessard & et al.¹⁴ analysed the utilization of FEA in the design of composite bicycle frames inferred that the values of 2.69 and 2.70 mm for the single bridge frame and the modified beam frame respectively are much less than the deflections upto 30 mm for the suspension system of mountain bikes which provides the rider, with a more comfortable ride than the metallic tubular frame.

2. EXPERIMENTAL WORK

2.1 Experimentation

In the present research work, Al - 4.5 wt. % Cu alloy having a theoretical density of 2800 kg/m³ is used as the base matrix. Fly Ash particulates with the theoretical density of 2300 kg/m³ and SiC particulates with the theoretical density of 3200 kg/m³ are used as reinforcements. The particulates size was evaluated by Scanning Electron Microscope Analysis as indicated in Figure.1 and 2.

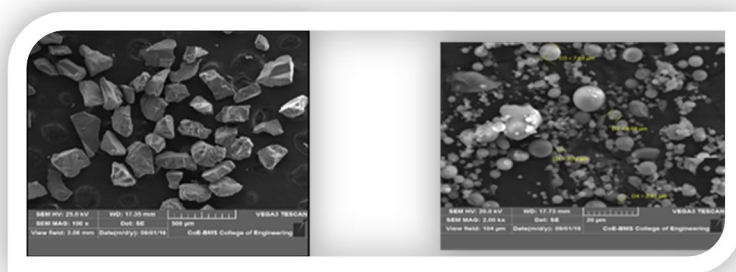

Fig.1

Fig.2

Fig. 1,2 Scanning electron microphotographs of SiC & Fly Ash particulates.

2.2 Fabrication of composites

Al-4.5% Cu alloy, which is the base alloy in the form of billets loaded into the graphite crucible and heated to 780 °C. The reinforcement of SiC particulates is weighed in the ratios of 5% & 7% by keeping the constant weight percentage of Fly Ash which was preheated to 400 °C to remove the moisture contents in the reinforcement. The reinforcements were preheated before adding to the aluminum alloy melt. The preheating of the reinforcement is necessary in order to reduce the temperature gradient and to improve wetting between the molten metal and the reinforcements. The molten metal mixture was degassed at a temperature of 780 °C using Hexa- chloroethane degassing

tablet. The tablet helps in the removal of entrapped air in the melt and thus prevents casting defects like porosity and blow holes. The molten metal matrix with the reinforcement was stirred using a Stirrer to create a vortex. 0.4% wt. of mg was added to ensure good wettability between the matrix and the reinforcement and the preheated reinforcements were added to the molten metal mixture with a continuous stirring speed of 300 rpm for a time of 3 minutes. The composite mixture was poured into the preheated cast iron die, and the die was placed in a compression testing machine. The plunger is assembled into the die, and a load of 120 MPa was applied for 4 minutes. The melt was then allowed to solidify in the molds to produce squeeze castings.



Fig. 3 Squeeze cast composites after removing from the molds

3. RESULTS AND DISCUSSIONS

The specimen is prepared for the tensile test as per ASTM standard (E8) to evaluate the mechanical properties like Yield Strength, Ultimate Tensile Strength, and Young's Modulus (E) of the material.

From the Tensile Test, the following data was obtained

For Base alloy (Al- 4.5% Cu alloy) E = 70 GPa

For MMC1 (3% Fly ash and 3% SiC) E = 80.44 GPa

For MMC2 (3% Fly ash and 7% SiC) E = 82 GPa

Table.1 Details of Mechanical Properties

SL No	Material	Yield Strength (MPa)	Ultimate tensile Strength (MPa)
1.	Base alloy (Al- 4.5% Cu alloy)	124	153
2.	MMC1 (3% Fly ash and 3% SiC)	142	178
3.	MMC2 (3% Fly ash and 7% SiC)	157	197

From the table, it is found that the MMC2 (3% Fly ash and 7% SiC) it has the highest value of Yield stress and ultimate tensile strength is 157 MPa and 197 MPa. Hence the material MMC2

(3% Fly ash and 7% SiC) is selected for the study of the Bicycle frame of different cross-sections like circular, Hollow circular section and T section as depicted in Figure (4 – 6).

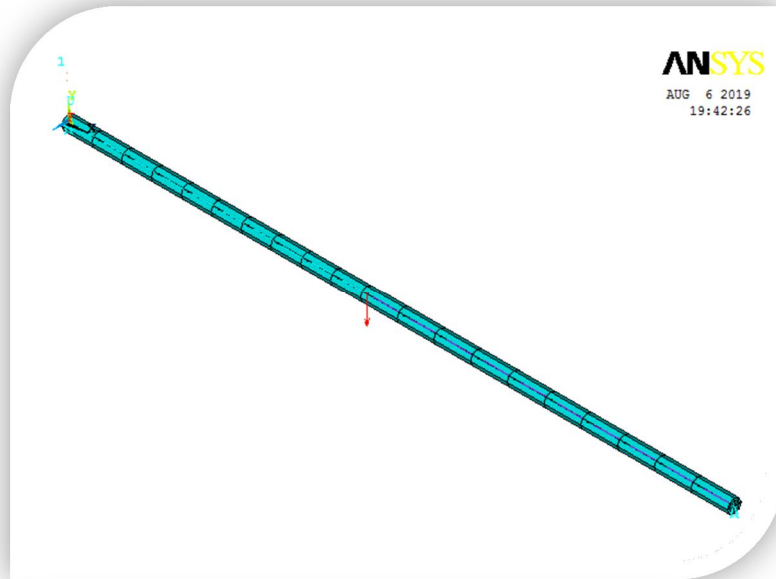

Fig. 4 Bicycle Frame of Circular Cross Section

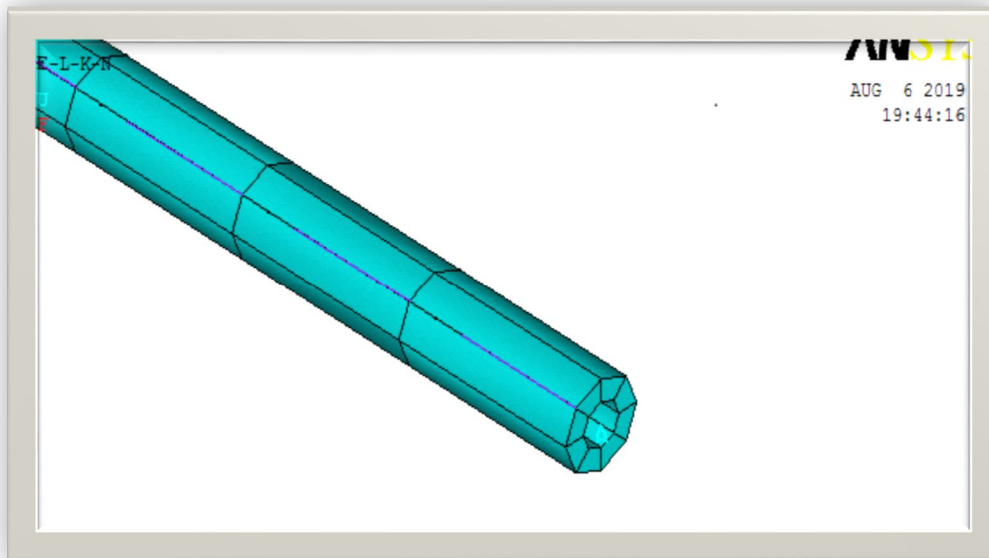

Fig. 5 Bicycle Frame of Hollow Circular Cross Section

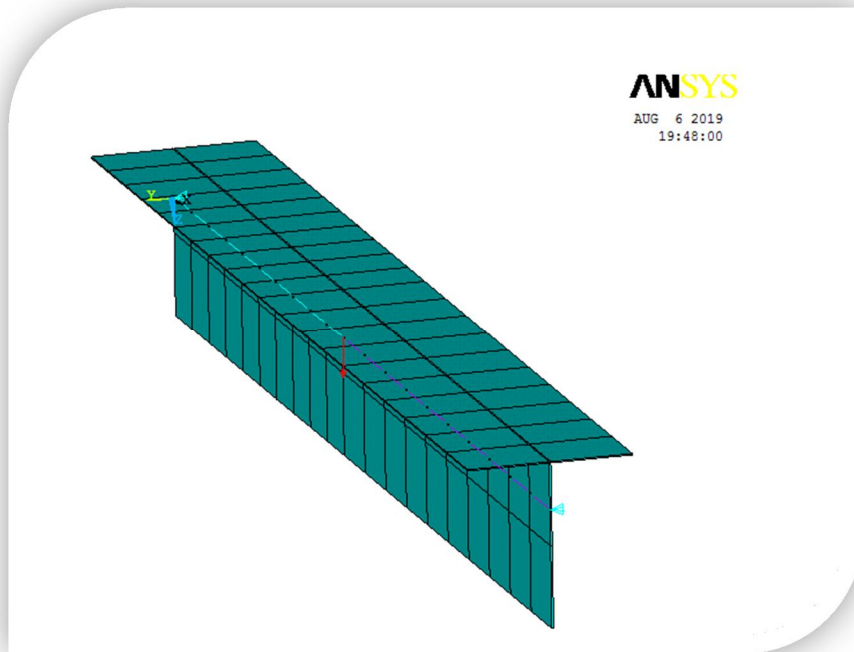

Fig. 6 Bicycle Frame of T- Section Cross Section

The bicycle frame is considered as a Simply Supported Beam, as shown in Fig 7, with the point load acting at the Centre and two supports applied at the ends.

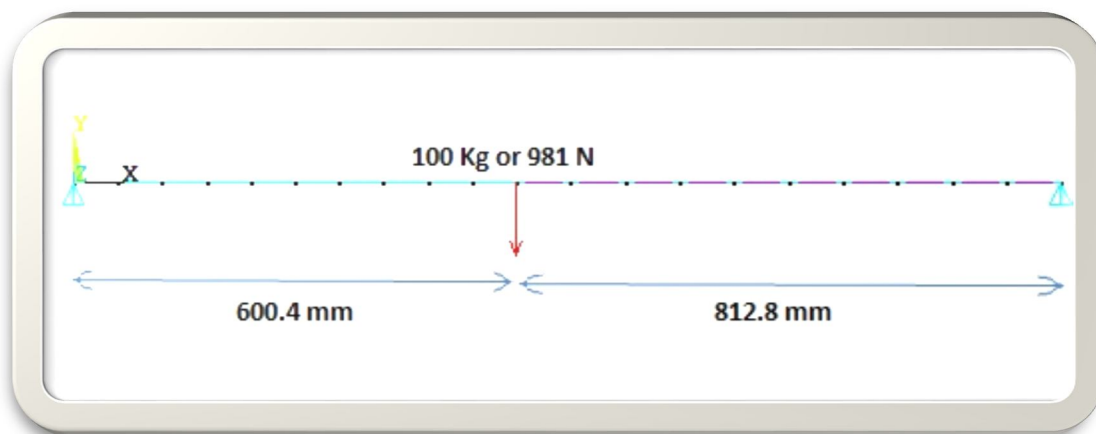

Fig. 7 Bicycle Frame considered as Simply Supported Beam

The Maximum load selected for the analysis is 100 Kg. From the test results, it is clear that for MMC2 yield strength of the material (σ_y), is found to be $\sigma_y = 157$ MPa. Considering a Factor of Safety of 2.0 for safe design. Therefore

Allowable stress, $\sigma_{\text{allowable}} = 157/2 = 78.5$ MPa. For Bicycle frame, the optimum area selected for all the cross-sections is 707 mm^2 .

4. CROSS-SECTIONS OF BICYCLE FRAME

For the optimum design, the effective cross-sections like Circular, Hollow Circular, and T

Section is analyzed for maximum deflection and Bending stress distribution using ANSYS Software as a tool.

4.1 Circular Cross-section

The deflection plot and von-mises plot for the circular section is represented in the Figure. 8 and 9.

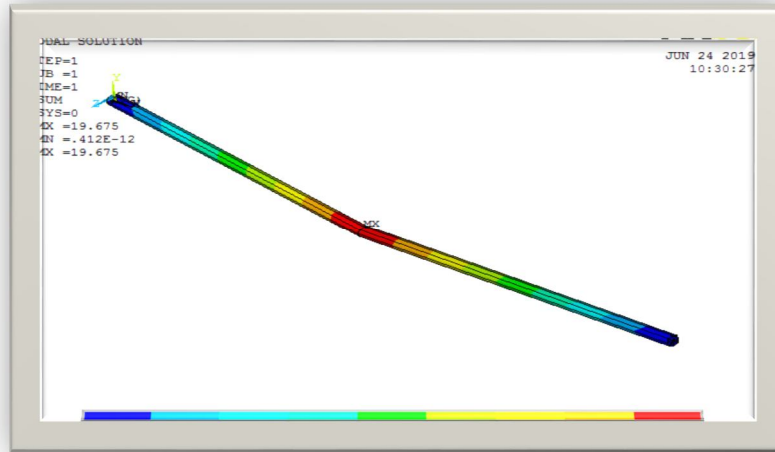

Fig. 8 Deflection Plot of Circular Section subjected to a load of 100 Kg

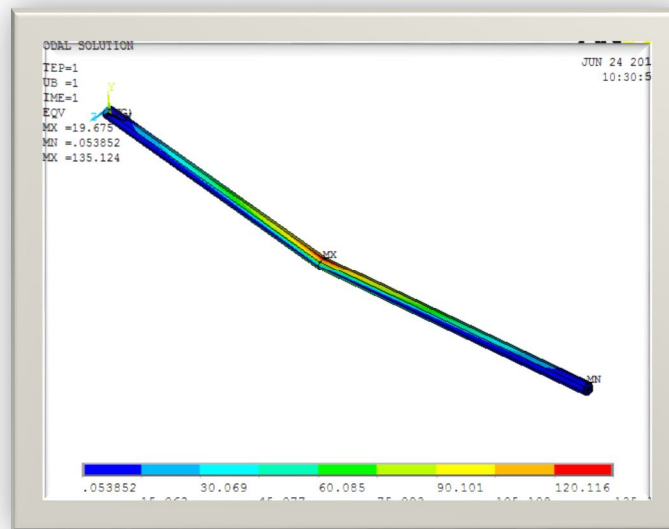

Fig. 9 Bending Stress Plot of Circular Section subjected to a load of 100 Kg

4.2 Hollow Circular Cross-section

The deflection plot and von-mises plot for the hollow circular section is clearly represented in the Figure. 10 and 11.

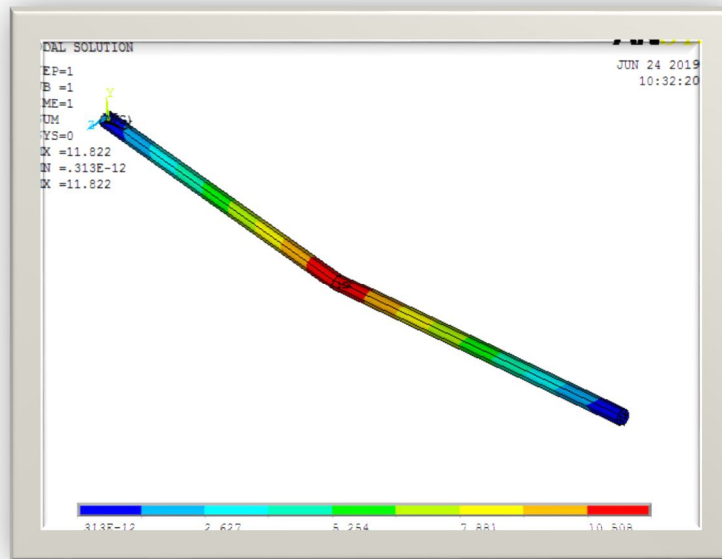

Fig. 10 Deflection Plot of Hollow Circular Section subjected to a load of 100 Kg

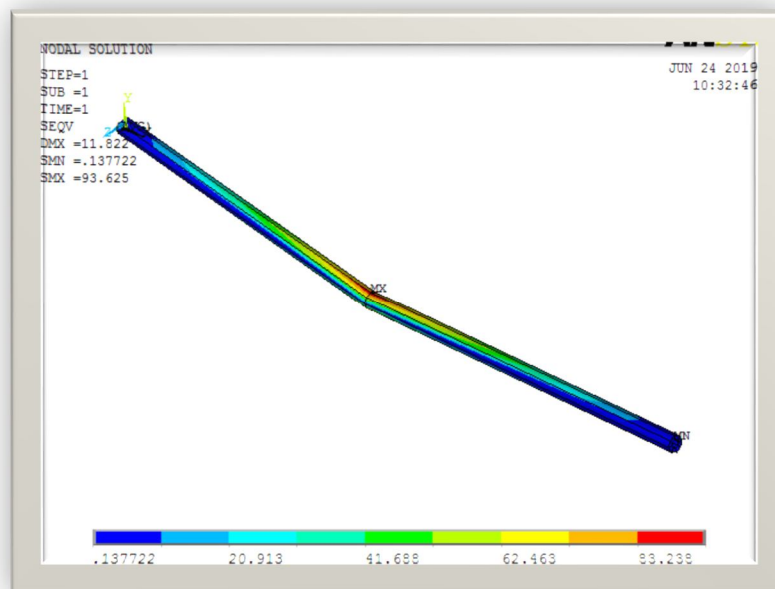

Fig. 11 Bending Stress Plot of Hollow Circular Section subjected to a load of 100 Kg

4.3 T –Section

The deflection plot and von-mises plot for the T section is represented in the Figure. 12 and 13.

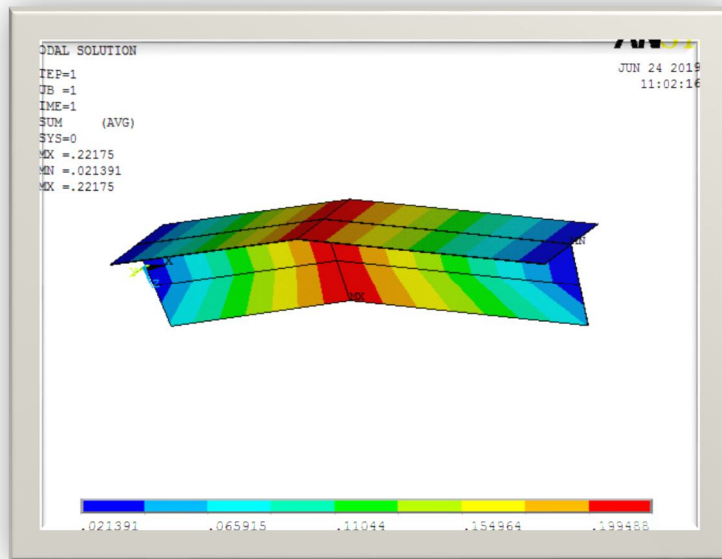

Fig. 12 Deflection Plot of T-Section subjected to a load of 100 Kg

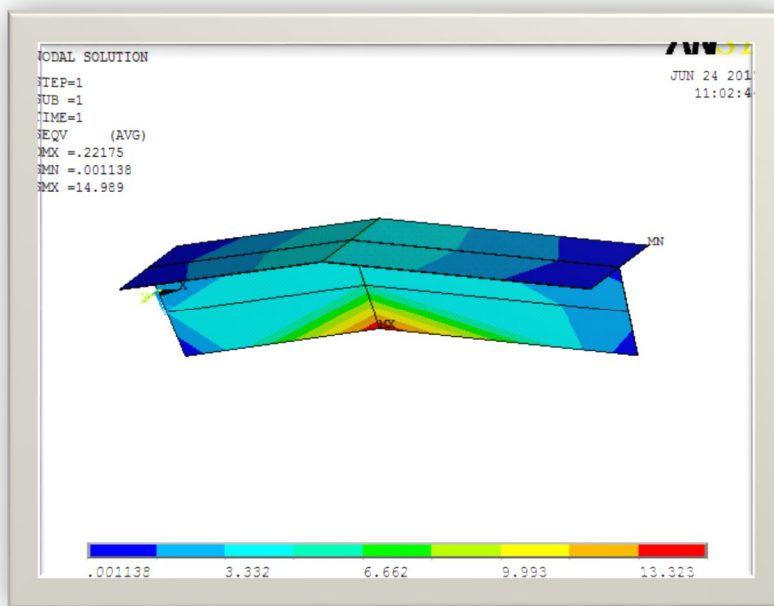

Fig. 13 Bending Stress Plot of T-Section subjected to a load of 100 Kg

Table.2 Analysis Results of Bicycle Frame

SL No	Cross-section	Deflection (mm)	Bending Stress (MPa)
1.	Circular	19.675	135.129
2.	Hollow Circular	11.822	93.625
3.	T Section	0.221	14.989

From the Table.2, It is clear that Circular Section and Hollow Circular Section fails to withstand the load of 100 Kg. As per the rule of design, the maximum induced stress is less than the

allowable stress of < 78.5 MPa

In this case, the Circular and Hollow Circular Section exceeded the allowable stress. Hence the T section is the suitable cross-section to bear the load of 100 Kg.

5. CONCLUSIONS

In the Present Investigation, Hybrid composites namely the base alloy (Al- 4.5% Cu alloy), MMC1 (3% Fly ash and 5% SiC) and MMC2 (3% Fly ash and 7% SiC) were produced by Stir Squeeze Cast technique has led to the following conclusions.

- Based on the Strength and Young's modulus, MMC2 is the optimum material for the Bicycle frame
- For the bicycle frame, Circular cross-section fails to withstand the allowable stress of 78.5MPa as the bending stress induced is found to be 135 MPa.
- For the bicycle frame, Hollow Circular cross-section fails to withstand the allowable stress of 78.5MPa as the bending stress induced is found to be 93.62 MPa
- For the bicycle frame, T section is the preferred cross-section as the Maximum Induced stress (14.98 MPa) and also in T section Top Flange will take the maximum load.
- For Dynamic Analysis, the deflection induced should be less than 3mm. Hence the T section is the preferred cross-section to bear the dynamic load also.
- Based on the results of Deflection and Bending stress, T section is the optimum cross-section for the Bicycle frame.

ACKNOWLEDGMENTS

The authors would like to extend their acknowledgetoBMS College of Engineering, India, and Jyothy Institute of Technology, for providing lab facilities.

REFERENCES

1. Bicycle industry takes MMC for a ride. Elsevier Science Ltd. 1995; 95: 30 -33.
2. Hoes, M., Binkhorst, R.A., Measurement of Forces Exerted on Pedal and Crank During Work on a bicycle Ergometer at Different Loads. *Int. Zeit.Ange. Physiol. Einschl. Arbeit.* 1968; 26: 33-42.
3. Soden, P.D., Adefeya, B.A. Forces Applied to a Bicycle During Normal Cycling. *J. Biomech.* 1979; 12: 527-541
4. Derek Covill, Philippe Allard, Jean-Mar Drouet, Nicholas Emerson. An Assessment of Bicycle Frame Behaviour under Various Load Conditions Using Numerical Simulations, *Procedia Engineering*, 2016; 147:665-670
5. Derek Covill, Alex Blayden, Daniel Coren, Steven Begg. Parametric finite element analysis of steel bicycle frames the influence of tube selection on frame stiffness. *Procedia Engineering*.

2015; 112:34-39.

- 6 Federico Giubilato, Valentino Franch, Nicola Petrone. Engineering evaluation of reactivity of racing bicycle wheels. *Procedia Engineering*.2014;72:489 – 49.
- 7 Joachim Vanwalleghem, Ives De Baere, Mia Loccufier, Wim Van Paepegem. Development of a multi-directional rating test method for bicycle stiffness.2014; 72: 321-326
- 8 Anton Koellnea, Christopher J. Cameron, Mark A. Battley. Measurement and analysis system for bicycle field test studies. *Procedia Engineering*. 2014; 72: 350-355
- 9 Derek Covill, Steven Begga, Eddy Eltona, Mark Milnea, Richard Morrissa, Tim Katza. Parametric finite element analysis of bicycle frame geometries. *Procedia Engineering*. 2014; 72: 441 – 446
- 10 Derek Covill, Steven Begga, Eddy Eltona, Mark Milnea, Richard Morrissa, Tim Katza. Parametric finite element analysis of bicycle frame geometries. *Procedia Engineering*. 2014; 72: 441 – 446.
- 11 Christopher J. Cameron, Mark A. Battley. Structural responses on a BMX racing bicycle. 2014; 72: 618 – 623.
- 12 R. R. Chang,,W.J. Dai, F.Y. Wu, S.Y. Jia, H.M. Tan. Design and Manufacturing of a Laminated Composite Bicycle Crank. *Procedia Engineering*.2013;67:497-505.
- 13 Alexandre Callens, André Bignonnet. Fatigue design of welded bicycle frames using a multiaxial criterion. *Procedia Engineering*. 2012; 34: 640 – 645.
- 14 Larry B. Lessard, James A. Nemes and Patrick L. Lizotte.Utilization of FEA in the design of composite bicycle frames. *Composites*.1995; 26 (1): 72- 74.