

International Journal of Scientific Research and Reviews

Fuzzy controlled SMES System for load leveling

Manisha^{1*} and Dahiya Anil²

¹Department of Electrical Engineering, UIET MDU, Rohtak, Haryana, India.

²Department of Electrical Engineering, NIT Kurukshetra, Haryana, India.

ABSTRACT:

A Superconducting Magnetic Energy Storage (SMES) is the latest energy storage device. SMES is an attractive option because there are no resistive losses in the superconducting coil and losses in the solid state power conditioning are minimal. When the AC networks requires a power boost, say when there are sags, spikes, load levelling, voltage and frequency instabilities, the coil discharges and acts as a source of energy. The DC voltage is converted back into AC voltage through the converter. This paper presents a fuzzy logic-controlled SMES for load levelling of an electric power system. In order to see how effective the proposed fuzzy controlled SMES in improving the load levelling is, its performance is compared to that of a conventional proportional–integral (PI) controlled SMES. Simulation results show that the performance of fuzzy controlled SMES is better than that of PI controlled SMES. Finally, it can be concluded that the proposed fuzzy controlled SMES provides a very simple and effective means of load levelling of electric power systems.

KEYWORDS: Superconducting Magnetic Energy Storage (SMES), Fuzzy Logic Controller (FLC), Load Levelling, Gate-turn-off (GTO), Proportional–Integral (PI).

***Corresponding Author**

Manisha

Department of Electrical Engineering, UIET MDU,
Haryana, Rohtak, India, Pin Code-124001.

E mail - er.ahlawatmanisha@gmail.com

Mob. No. - 9416927515

INTRODUCTION:

Intensive progress in power electronics and superconductivity has provided power transmission and distribution industry with superconductive magnetic energy storage (SMES) units. Since the successful commissioning test of the BPA 30-MJ unit¹, SMES systems have received much attention in power system applications, such as, diurnal load demand levelling, frequency control, automatic generation control, uninterruptible power supplies, etc. The real power can be absorbed or released from the low loss superconducting magnetic inductor according to system power requirements. The amount of energy to be supplied or received by the SMES unit can be controlled by the firing angle of the converters of the SMES unit. By using high-speed electronic switches, the technology offers many chances for stability enhancement of power systems. The thyristor controlled SMES unit is also such a device. A number of articles have been reported demonstrating the use of SMES unit for load levelling. However, in all of these works, SMES is controlled through conventional controllers. The effectiveness of SMES on power system stabilization depends on its proper control strategy. Fuzzy logic is a powerful problem-solving methodology with a myriad of applications in embedded control and information processing. Fuzzy logic resembles human decision making with its ability to work from approximate data and find precise solutions. The control method of modelling human language has many advantages, such as simple calculation, high robustness, lack of a need to find the transfer function of the system, suitability for nonlinear systems, etc. Therefore, considering these views, this paper presents a fuzzy logic switching of the thyristor controlled SMES for load levelling of an electric power system. In order to see how effective the fuzzy controlled SMES unit for load levelling is, its performance is compared to that of a conventional proportional-integral (PI) controlled SMES scheme. As a whole, the distinguishing features of this paper are as follows: 1) the use of fuzzy logic concept for SMES control; 2) the performance comparison between the fuzzy controlled SMES and the PI controlled SMES.

MODEL SYSTEM:

For the simulation of load levelling, the model system, as shown in Figure 1, has been used in this paper. The Power system model having 3-phase voltage source of 11KV connected to a fixed load of 100 MW through a transmission line having a impedance .00005 pu and resistance .001 pu. As in model in Sim Power Systems of MATLAB for the purpose of the study of SMES performance for load levelling a load 2.2MW for the duration of 0.5s (i.e. 1s to 1.5s).

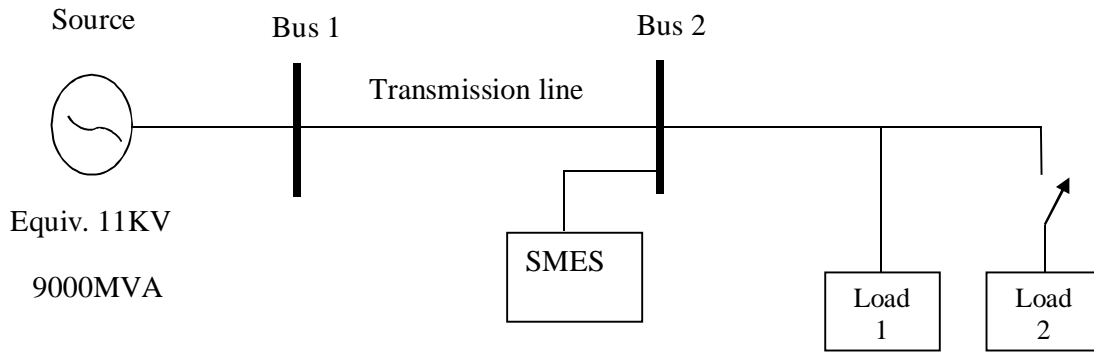

Figure 1 Single line diagram of Power System

MODELING OF SMES:

The model of SMES consist 3-phase thyristor control converter and a superconducting coil of inductance 2H and resistance .01Ω has been modelled in MATLAB environment. In thyristor control converter bridge, six controlling pulse given by synchronized 6-pulse generator are given. The synchronization of 6-pulse is for an alpha angle of 0 degree. The pulses are generated exactly at the zero crossing of the three line to line synchronization voltages. The pulse ordering at the output of the block corresponds to the natural order of commutation of a three-phase thyristor bridge. Alpha is given to the controller input to control the pulses timing of the converter. The phase-to-phase synchronization voltages V_{ab} , V_{bc} and V_{ca} is achieved with the help of a PLL tracking. The synchronization voltages should be in phase with the three phase-phase voltages at the converter AC terminals. Synchronization voltages are normally derived at the primary windings of the converter transformer. The fundamental frequency control technique has been used for converter control. The pulses are disabled when the applied signal is greater than zero.

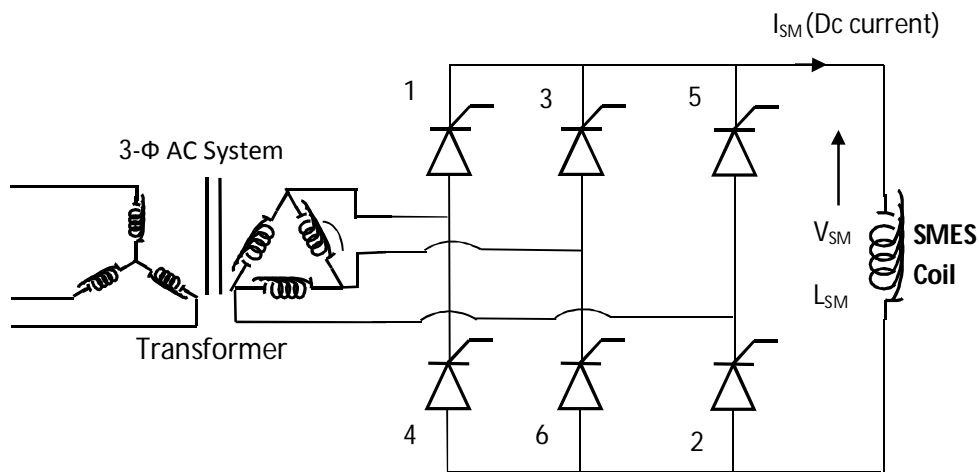

Figure 2 SMES model

DESIGN OF FUZZY LOGIC AND PI CONTROLLERS:

The fuzzy logic, unlike the crispy logic in the Boolean theory that uses only two logic levels (0 to 1), is a branch of logic that admits infinite logic levels (from 0 to 1), to solve a problem that has uncertainties or imprecise situations². Again, a fuzzy control is a process control that is based on fuzzy logic and is normally characterized by “IF-THEN” rules. The design of the proposed fuzzy logic controller (FLC) is described in the following.

Fuzzification: The fuzzification procedure consists of finding appropriate membership functions to describe crisp data. For the design of the proposed FLC, power mismatch, Δp , and firing angle of thyristor, α , are selected as the input and output, respectively. Triangular membership functions for are shown in Figure 3, in which the linguistic variables N, Z, and P stand for negative, zero, and positive, respectively. The membership functions have been determined by the trial and error approach in order to obtain the best system performance. The equation of the triangular membership function used to determine the grade of membership values is as follows³:

$$\mu_{Ai}(x) = 1/b(b-2 | x-a |)$$

where $\mu_{Ai}(x)$ is the value of grade of membership, “b” is the width, “a” is the coordinate of the point at which the grade of membership is 1 and “x” is the value of the input variable.

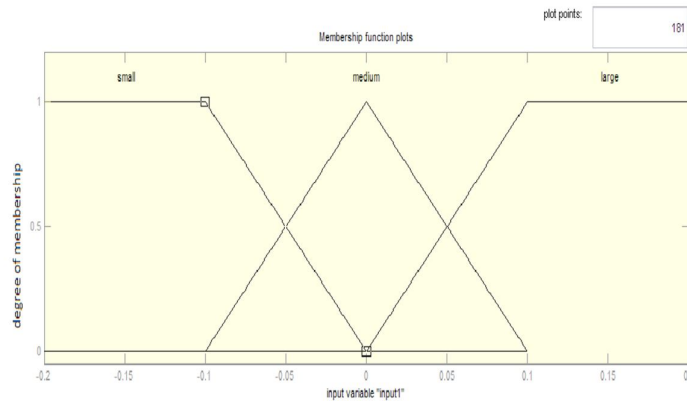

Figure 4 Membership functions of Δp (pu) for SMES.

Fuzzy rule base: The rule base is the heart of a fuzzy controller, since the control strategy used to control the closed-loop system is stored as a collection of control rules. The specific feature of the proposed fuzzy controller is its very simple design having only one input variable and one output variable. The use of the single–input, single–output (SISO) variable makes the fuzzy controller very straightforward^{4,5}.

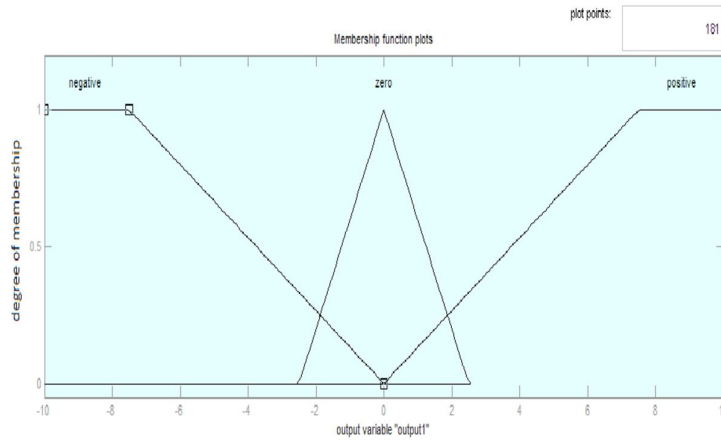

Figure 5 Membership functions of $\alpha(\text{degree})$ for SMES.

Figure 5 shows the membership functions for the output variable consisting of three singleton fuzzy sets SMALL, MEDIUM, and LARGE. The control rules of the proposed controller are determined from the viewpoint of practical system operation and by trial and error and are shown in Table no. 1.

Table No. 1: “Fuzzy rule table for SMES”

S. No.	Power mismatch(Δp)	A
1	SMALL	N
2	MEDIUM	Z
3	LARGE	P

Fuzzy Inference: The basic operation of the inference engine is that it infers, i.e., it deduces (from evidence or data) a logical conclusion. Actually, the inference engine is a program which uses the rule base and the input data of the controller to draw the conclusion. The conclusion of the inference engine is the fuzzy output of the controller, which subsequently becomes the input to the defuzzification interface. For the inference mechanism of the proposed FLC, Mamdani’s method⁶ has been utilized. A fuzzy rule typically has an IF-THEN format as follows:

IF(X_1 IS A_i and X_2 IS B_i) THEN

$$Z_1 = C_i, \quad i = 1, 2, 3, \dots, r$$

where X_1 and X_2 are fuzzy input variables, Z_1 is the fuzzy output variable, is the rule number, r is the total number of rules, A_i , B_i and C_i are fuzzy subsets in the universe of discourses X , Y and Z respectively. Therefore, according to Mamdani, the degree of conformity W_i , of each fuzzy rule is as follows:

$$W_i = \mu_{A_i}(X_1) \times \mu_{B_i}(X_2)$$

where $\mu_{A_i}(X_1)$ and $\mu_{B_i}(X_2)$ are the values of the grade of membership.

Defuzzification: In this last operation, the fuzzy conclusion of the inference engine is defuzzified, i.e., it is converted into a crisp signal. This last signal is the final product of the FLC which is, of course, the crisp control signal to the process⁷. The centre-of-area method is the most well-known and rather simple defuzzification method which is implemented to determine the output crispy value. This is given by the following expression:

$$Z = \frac{\sum W_i C_i}{\sum W_i}$$

where Z is the crispy output function and C_i is already defined in the previous section.

PI Controller:

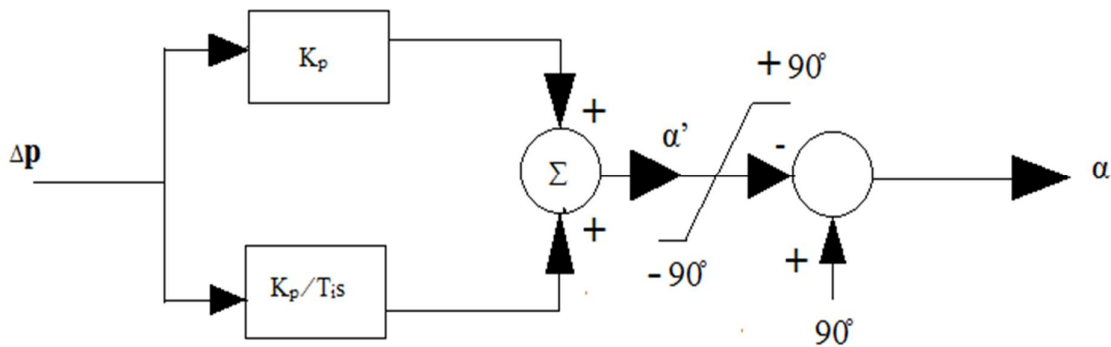

Figure 6 Block diagram of PI controller

Table 2 Parameter of PI controller

S. No.	K _p	T _i
1	180.0	0.0124

SIMULATION RESULTS AND DISCUSSIONS:

A 3-phase utility has been considered and studied analytically with a Fuzzy controller. The simulation of this model is carried out in Simulink/ MATLAB. The results from simulation are presented in Figures 7 to 9.

Simulated data: rated voltage=11kV/ph, frequency=60 Hz, with transmission line resistance .001pu and inductance .00005pu. Thyristor based 6-pulse converter, DC side voltage = 11kV, pulse width = 26 degree. Fixed load of 100MW star connected, three phase breaker transition time=0.5s (i.e. 1 to 1.5s), breaker resistance=.001Ω and snubbers resistance=1000000Ω. Load through CB of star grounded, 2.2MW is star grounded. SMES inductance=2H, resistance=.01Ω, inductor initial current=6000A.

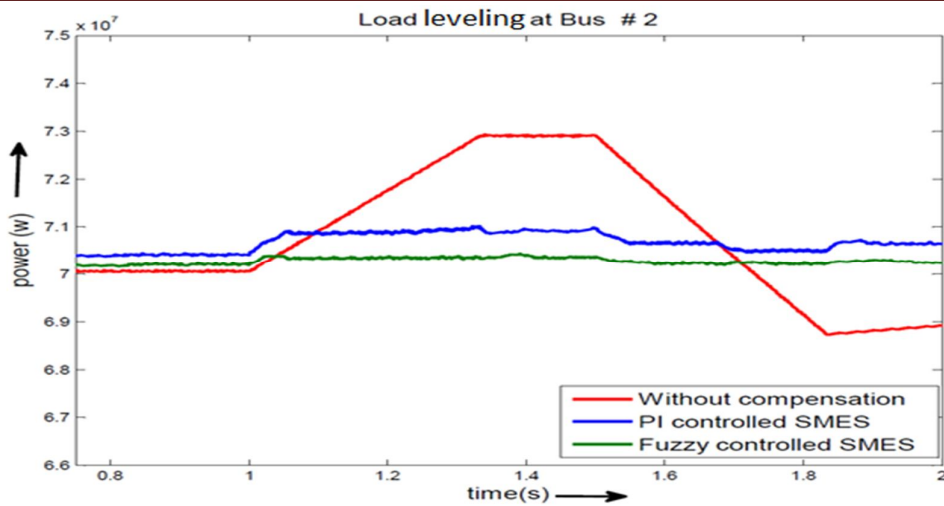

Figure 7 Load Levelling at bus 2 with and without compensation

In the above Fig.7.1 load levelling at bus 2 where the additional load is connected to the power system through CB then the load will increase to compensate this increased load in power system. To compensate this increased load, SMES will discharge up to 1.5sec at that point CB is OPEN additional load will be removed from the power system. The load compensation is better in case of Fuzzy controlled SMES than the PI controlled SMES.

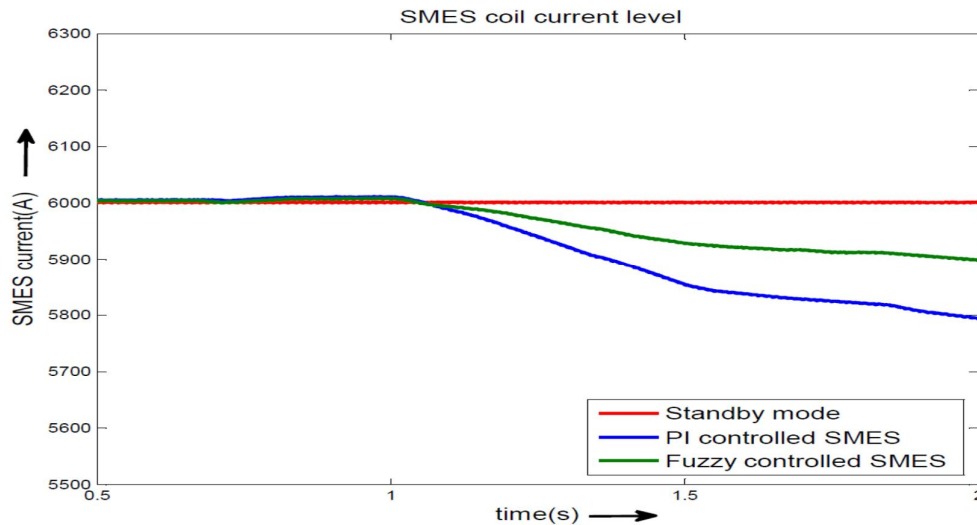

Figure 8 Current Level of SMES coil

In the above Figure 8 SMES current is in standby mode and is constant at its initial current but in case of Fuzzy controlled and PI controlled SMES will discharge and the current drops for 0.5 sec (i.e. 1sec to 1.5 sec CB is CLOSED). The results of SMES current level are better in case of Fuzzy controlled SMES than PI controlled SMES.

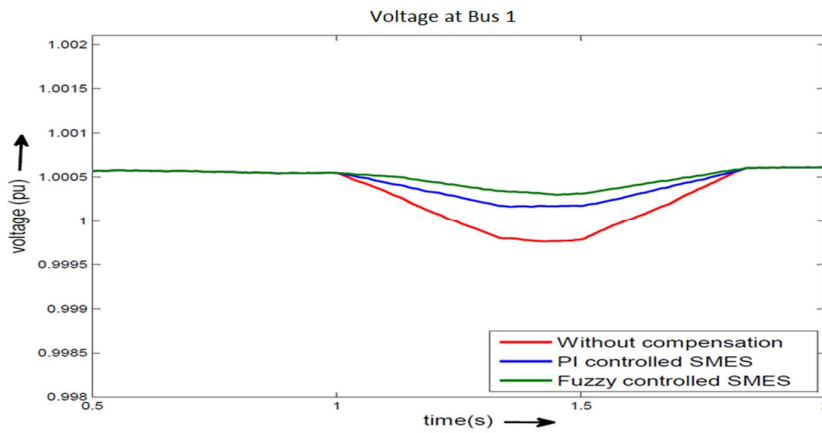

Figure 9 Voltage at bus 1 with and without compensation

In the above Figure 9 voltage at bus 1 is constant at pu value up to 1sec but at 1sec when the circuit breaker is CLOSED the additional load is connected to the system and there is drop in the voltage at that time SMES will discharge: After 1.5 sec circuit breaker will OPEN and the voltage recovers and reaches its pu value. The waveform of voltage is good in Fuzzy controlled SMES than the PI controlled SMES and without compensation.

CONCLUSION:

In the present work Fuzzy Logic Controller is used to control the operation of thyristor based SMES to proceed the load levelling in Power System. The SMES and Power System have been modelled using SimPowerSystem of MATLAB and a Fuzzy Logic Controller has been modelled using “Fuzzy” tool of MATLAB. MATLAB simulation has been carried out and results have been analysed. It has been observed that the Fuzzy controlled SMES has provided load levelling effectively. Further, the performance of SMES with Fuzzy Logic Controller has been observed to be better as compared to PI controlled SMES.

REFERENCES:

1. Boenig H. J. and Hauer J. F. Commissioning tests of the Bonneville power administration 30 MJ superconducting magnetic energy storage unit. IEEE Trans. Power App. Syst. Feb. 1985; PAS-104(2):302–309.
2. Langari Rem. Past, present and future of fuzzy control: A case for application of fuzzy logic in hierarchical control. IEEE 1999;760- 765,.
3. Driankov D., Hellendoorn H. and Reinfrank M. An Introduction to Fuzzy Control. Berlin, Germany: Springer-Verlag, 1993.

4. Ali M. H., Murata T. and Tamura J. The effect of temperature rise of the fuzzy logic-controlled braking resistors on transient stability. *IEEE Trans. Power Syst.* May 2004;19, (2):1085–1095.
 5. Ali M. H., Soma Y., Murata T. and Tamura J. Transient stability improvement by fuzzy logic controlled braking resistor. *Int. J. Power Energy Syst.* 2005; 25,(3): pp. 143–150.
 6. Mamdani E. H. Application of fuzzy algorithms for simple dynamic plant. *Proc. IEE* 1974;121:1585–1588.
 7. Ibrahim Ahmad M. *Fuzzy Logic for Embedded Systems Application.* Elsevier science (USA)-2004.
 8. Kundur Prabha. *Power System Stability and Control.* EPRI, Tata McGraw-HILL.
-