

International Journal of Scientific Research and Reviews

Impacts of Commercial Shrimp Farming on Land-cover Change in the Coastal Blocks of Purba Medinipur District, West Bengal (India) – A Study Based on Remote Sensing and GIS Approach

Ojha Atanu^{1*} and Chakrabarty Abhisek²

Dept. of Remote Sensing & GIS, Vidyasagar University, Midnapore -721102 West Bengal, India.
Email: atanuojha@gmail.com

ABSTRACT

Shrimp farming is playing a great role in present Indian economy. It has a huge contribution to the economy of a developing country like India but is always subjected to some adverse environmental consequences. The present study is focused on rapid growth in commercial shrimp farming in five coastal blocks of Purba Medinipur, West Bengal (India) and its influence on land cover changes. This work has been done by analyzing multi-temporal satellite data of year 2008, 2012 and 2016 and quantifying all land cover classes of the study area. Hence, the sequence of successive changes in land cover types can be visualized clearly. All the land cover classes under study area are obtained for the years 2008, 2012 and 2016 by visual image interpretation. With the help of change detection matrix, trajectories of land cover classes are focused. Everything is carefully done in remote sensing and GIS platform. This study has also pointed out the drastic change in the total area of shrimp farming. The total area of shrimp farming was 4234.13 ha in 2008 and has increased to 5895.40 ha in 2016. This major change has been noticed from the year 2012 to 2016 in which the farming area has drastically widened by 1175.54 ha but on the other hand, the agricultural land is reduced by 1414.95 ha. Between the years 2008 and 2016 agricultural land has decreased by 1945.31 ha in which 1542.48 ha was replaced by shrimp farming. This change always goes through a controversy among the researchers of different domains, and the burning question is now whether to focus on economic growth with shrimp farming or to save our environment by taking some suitable measures to control the future environmental degradation.

KEYWORDS: Shrimp farming, Brackish water tanks/ponds, Agricultural land, Land-cover change, Remote Sensing and GIS.

***Corresponding author**

Atanu Ojha

Research Scholar,

Dept. of Remote Sensing & GIS, Vidyasagar University,

Midnapore-721102, West Bengal, India.

Email: atanuojha@gmail.com

INTRODUCTION

Human activities on earth have always influenced a change in its natural landscape. The continuous growth of commercial shrimp farming in coastal areas causes a change in the natural landscape of the nearby areas and it also has its adverse impact on traditional agriculture and coastal ecosystem. In India, this rapid growth of shrimp farming is a triggering force on land cover changes in the coastal areas, which are already depicted on many research works¹⁻⁵. Nowadays shrimp farming is in high demand worldwide, which encourages people to do it more and more. The net profit earned from shrimp farming is 12 times higher than the profit earned from rice cultivation⁶. Therefore, the highly populated areas of tropical Asia and Latin America have also converted to shrimp farming, changing the land cover portion drastically⁷⁻⁹. For the quantitative analysis of land cover changes, satellite image is the most useful data source. By visualizing the pattern of land cover of a particular area, human activity and its interaction with the environment can be easily understood. Remote sensing and GIS are very important tools for the detection of land cover changes and to collect data related to land cover changes¹⁰⁻¹². Remote sensing is such a technique in which spatial and temporal data of a wide geographic area can be collected smoothly without doing any field visit¹³⁻¹⁴. With the analysis of remote sensing data of temporal series and change trajectories, dynamic change investigation can be done¹⁴⁻¹⁵. From change detection matrix changes of a particular area can be noticed significantly.

The geographical location and climatic condition of Purba Medinipur district of West Bengal, India, is considered as highly productive areas of the country, both in case of agriculture and aquaculture. Initially, utilizing the saline water, shrimp farming had been done in coastal lowland areas. But with continuous increase of its demand and realizing the profit margin of shrimp culture people has already started doing shrimp farming, not only in lowland coastal areas but also in the areas which are far from the coast by using the saline water. Because of this, agriculture land of those areas has been converted to brackish water (Bw) tanks/ ponds.

The objectives of the present study are i) To depict the present status of shrimp farming in five coastal blocks of Purba Medinipur district of West Bengal, India by using remote sensing and GIS technique, ii) Detailed classification of water bodies to separate the brackish water tanks/ponds (shrimp farm) from other water bodies, and iii) To identify and quantify the land cover changes from year 2008 to 2016 in which the shrimp farming shows great impact.

STUDY AREA

Study area of this project is located in southeastern part of Purba Medinipur district of West Bengal, India. This is spread along the shoreline of Bay of Bengal and comes under Kathi coastal

plain and consists of five coastal blocks of Contai sub-division. Those are Contai I, Desopran (Contai II), Contai III, Ramnagar I and Ramnagar II respectively. Geographically the study area is located on 21°36'20.67"N to 21°55'17.97"N latitude and 87°26'31.71" E to 87°53'39.76"E longitude (Fig 1). The area is approximately 818 sq km (81806 ha).

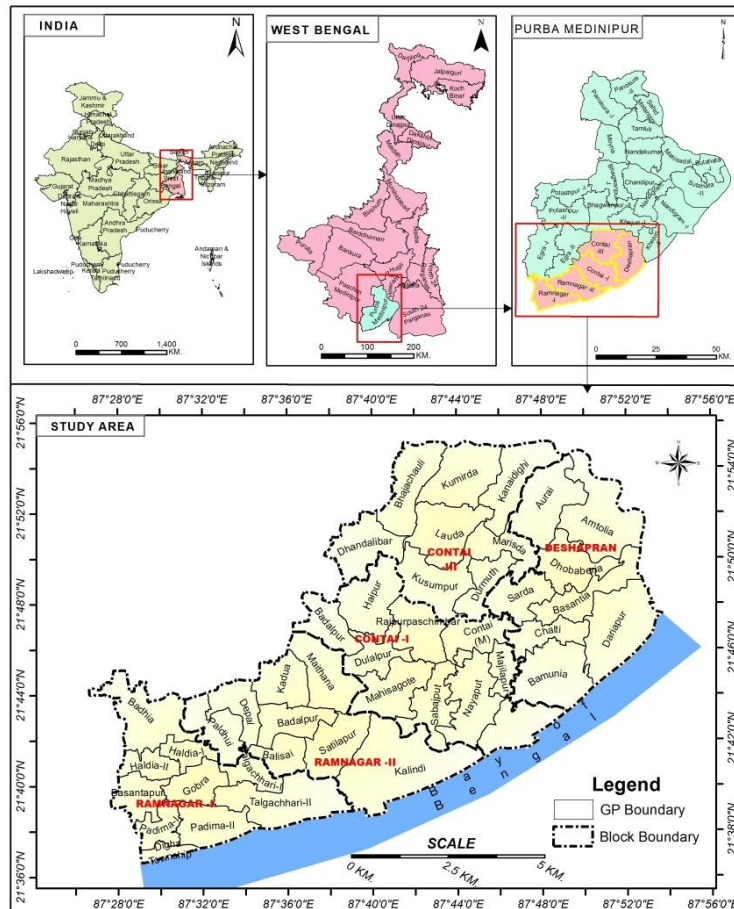

Figure 1: Location map of the study area

The study area consists of total 849 Mouzas, 42 Gram Panchayats (GP) and 1 Municipality. The coastal line is about 50 km in length. This area is nearly a flat surface with an average elevation of 5m to 7m above the mean sea level. Sand dunes are sometimes noticed because of fluvial and tidal activities. Rasalpur River, Odisha Coast Canal, Contai Canal, Pichaboni Khal are the main riverine systems of the study area. By using the saline water of those river/canal shrimp culture is done in the nearby areas. Paddy is the major crop of the study area. Apart from that, the area also produces different vegetables, betel leaf, cashew nuts etc. Maximum people are involved in agriculture, while some people involved in aquaculture and sea fishing and others are involved in tourism business. The main tourist spots of the area are Digha, Sankarpur, Tajpur, Mondarmani, Udaypur and Junput.

DATA AND METHODOLOGY

The work under interest has been done in two steps. In the first step, the high-resolution satellite image is collected and georeferenced for the years 2008, 2012 and 2016. In the year 2016 total 1810 nos of image tiles (Red, Green, Blue) are collected from Google Earth using Elshayal Smart software (Fig 2). The advantage of this software is that the collected image tiles are locally referenced. All the tiles are mosaiced and converted to a single image by using Erdas Imagine 11 software. Similarly, satellite images for the years 2012 and 2016 are collected by changing the time scale of Google Earth. These images are collected between the months of August to November, which is the most active period for shrimp farming. For georeferencing of the images, 24 nos of well-distributed ground control points (latitude and longitude) are collected with the help of GPS. With these ground control points (GCP) georeferencing of the images has been done. For the current purpose UTM projection, WGS 84 datum is used. Administrative boundary wise information is taken from police station maps (1inch =1 mile) of the study area which has been georeferenced with respect to the images.

In the second step to get the year wise land cover status, the images are classified into twelve different classes with the help of on-screen digitization. As the primary focus of the study is shrimp culture, the water bodies of the selected area are divided into six different land cover classes. On the basis of image elements (tone, shape, size, pattern, texture, and association) and following classification scheme of National Remote Sensing Agency (NRSA 1995) all collected images of the years 2008, 2012 and 2016 are classified (Table 1). Georeferencing and image classification are done in Arc GIS 10.2 environment. To verify the accuracy of land cover classes, 4 samples (spot) of each individual class are randomly checked during field verification.

With the help of change, detection matrix and using the land cover layers of years 2008, 2012 and 2016; the change of land cover is shown with respect to the change in time and place. Simultaneously with the help of change detection matrix land cover “change” trajectories (from-to) and “no-change” areas are marked. For change detection matrix QGIS desktop 2.18.16 software is used. The flow diagram of land cover classification and change detection matrix is shown in Figure 3.

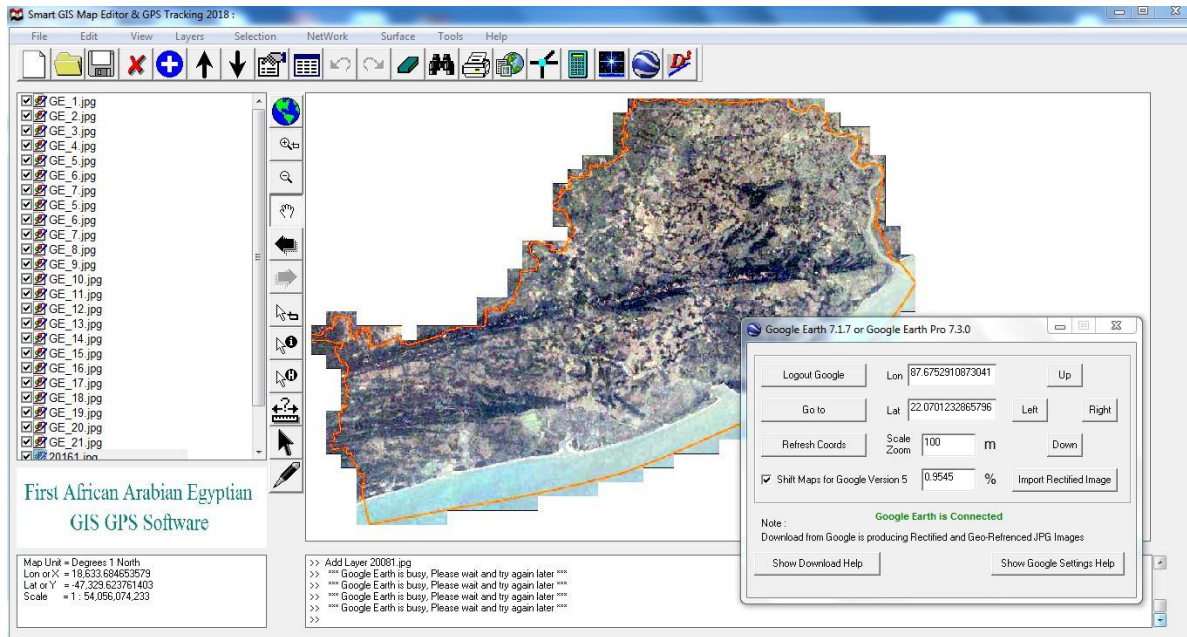

Figure 2: Google Earth image of the study area (year-2016)

Table 1: Details of the Classification Scheme

Level I	Level II	Level III	Acronym
Water bodies /Wetland	Aquaculture pond	Fresh water Tanks/Ponds	Fwtp
		Brackish water Tanks/Ponds	Bwtp
		Nayanjuli (Roadside ditch)	Nj
	Sea/River/Stream/Canal	River/Stream/Canal	W
		Sea	S
	Wetland	Waterlogged area	Wl
Agricultural land	Agricultural land	Agricultural land	Ag
Forest	Plantation	Vegetation Cover	Vc
	Evergreen/Semi evergreen		
Barren/Unculturable/ Wasteland	Sandy area	Sandy area	Sa
	Scrub Land	Scrub Land	Sl
Builtup	Rural/Urban/Industries	Settlement	Sm
		Transportation	Tp

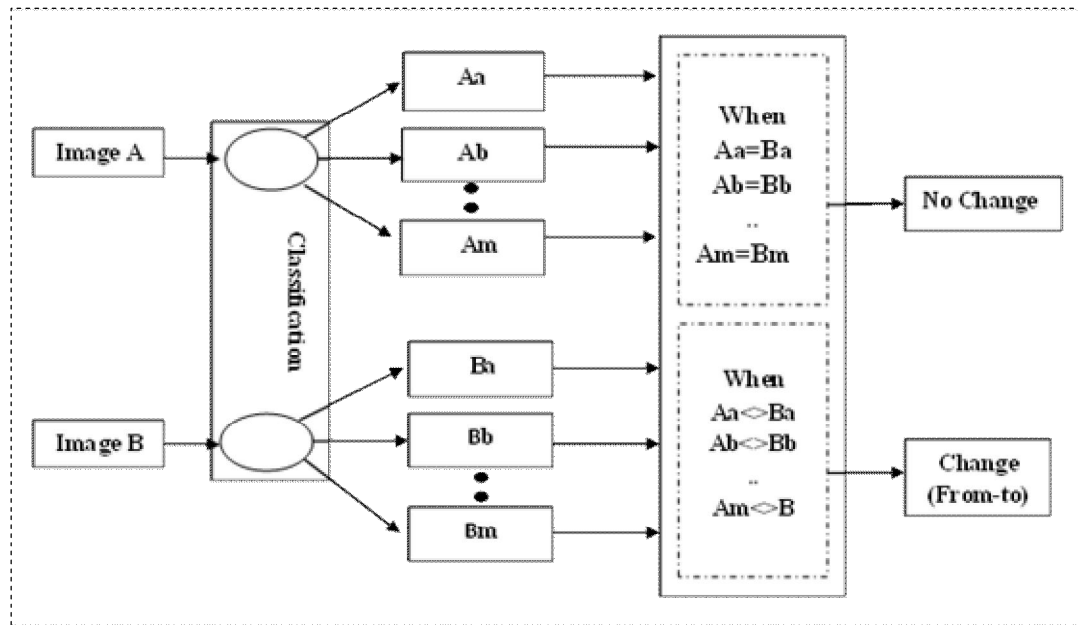

Figure 3: Flow diagram for change detection matrix

RESULTS AND DISCUSSION

The continuous growth of shrimp farming area is estimated by using multi-temporal high-resolution Google Earth imageries. To separate the water bodies of shrimp farming high-resolution imageries are required and for that Google Earth is the best possible option because of free availability of its data. The spatial distribution (Fig 4) and area wise statistics (Table 2) of all the land cover classes of the study area are obtained by the GIS data base which is acquired by land cover classification. This is done for the year 2008, 2012 and 2016.

Between 2008 to 2016 rapid increase of brackish water tanks/ponds has been noticed which means shrimp farming has grown drastically during this period. Simultaneous with this increment of brackish water tanks/ponds, the agriculture land of the study area has reduced dramatically. The highest change has been visualized in between the year 2012 to 2016. 1661.27 ha of total brackish water tanks ponds have increased in between the year 2008 to 2016, out of which 1175.54 ha have increased in the last four years (2012-2016). Total 1945.31 ha of agricultural land has reduced from 2008 to 2016, and the drastic change is noticed in the last four years (2012 to 2016) in which it is reduced by 1414.95 ha. Among all five blocks of study area, Desopran block (Contai II) and Contai III block have experienced abrupt change. The land cover classes in which positive changes have noticed are - settlement (278.03 ha), fresh water (Fw)tanks/ponds (119.04 ha), scrub land (5.72 ha).

The classes which experienced negative changes (-) are vegetation cover (38.77 ha), sandy area (49.29 ha) and river/stream/canal (26.39 ha), Nayanjuli (4.31 ha). Almost no changes have been noticed in transportation, sea, waterlogged areas.

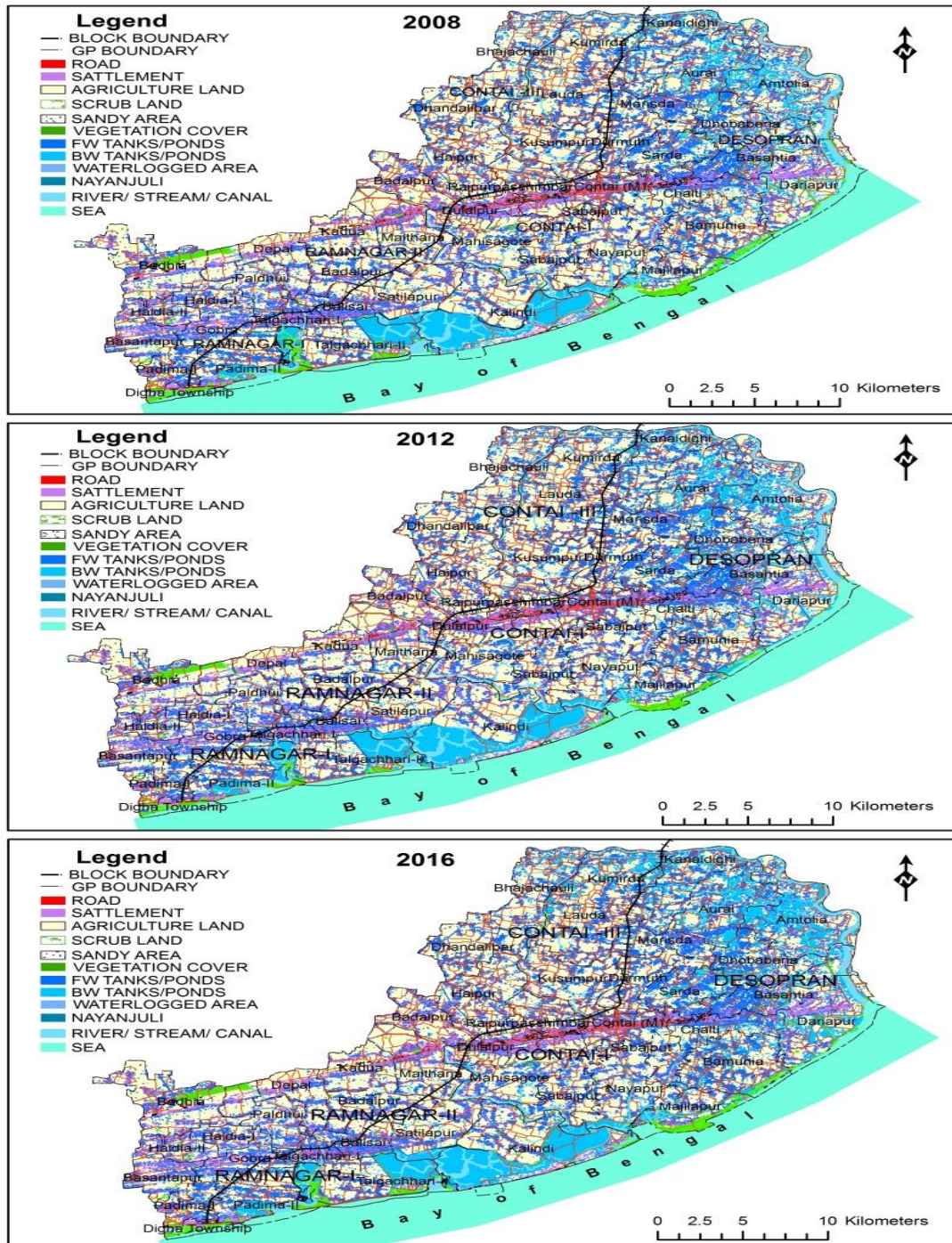

Figure 4: Land-cover maps of year 2008, 2012 and 2016

Table 2: Land-cover statistics of year 2008, 2012 and 2016

Sl no	Land-cover category	Area in ha			Area change in ha		
		2008	2012	2016	2008 to 2012	2012 to 2016	2008 to 2016
1	Agriculture land	47990.56	47460.20	46045.25	-530.36	-1414.95	-1945.31
2	Bw tanks/ponds	4234.13	4719.86	5895.40	485.72	1175.54	1661.27
3	Fw tanks/ponds	3675.18	3707.55	3794.21	32.37	86.66	119.04
4	Settlement	18924.31	19006.74	19202.34	82.43	195.60	278.03
5	River/ stream/ canal	2330.29	2304.36	2303.90	-25.93	-0.46	-26.39
6	Transportation	963.73	963.73	963.73	0.00	0.00	0.00
7	Sandy area	379.39	359.45	330.10	-19.95	-29.35	-49.29
8	Scrub land	344.56	336.22	350.28	-8.34	14.07	5.72
9	Sea	1383.94	1383.94	1383.94	0.00	0.00	0.00
10	Nayanjuli	294.98	291.88	290.67	-3.10	-1.21	-4.31
11	Vegetation cover	1278.97	1266.11	1240.19	-12.85	-25.92	-38.77
12	Waterlogged area	8.54	8.54	8.55	0.00	0.01	0.01

On pixel by pixel analysis of the classification images of two years, a change detection matrix has been obtained for that particular pair of observation year. Change detection matrixes are shown in Table-3 and Table-4 for the year 2008 to 2012 and 2012 to 2016 respectively. The diagonal values of the matrix indicate no change areas. With the help of this matrix the change of one land cover class to another land cover classes are determined (from-to) and also its statistical values of the change can be obtained (Table 5).

By analyzing the change detection matrix of this study dynamic change of shrimp farming has been noticed. 1546.54 ha agriculture land, 31.35 ha vegetation cover, 18.09 ha fresh water tanks/ponds and 17.75 ha of scrub land, 17.30 ha of sandy area has been converted into brackish water tanks/ponds. Apart from these 26.29 ha areas of river/ stream/canal has been changed into brackish water tanks/ponds. According to the data of change detection matrix, agriculture land has experienced the highest change. It is not only affected by shrimp farming but a significant area has also converted to settlement and fresh water tanks/ponds. 266.18 ha converted to settlement area and 131.28 ha converted to fresh water tanks/ponds. Land cover change map for the periods (a) 2008-2012,(b) 2012-2016 are shown in Figure-5. This statistical analysis not only explains the changes in land cover areas but also indicates the socio-economic change, the environmental impact as well as the future trend. This change is influencing the economic growth, but on the other side, it has badly the production of rice in that area, which is the main crop of the study area.

The conversion of agriculture land into shrimp farming land has directly affected the rice field area and saline water flowing to the agriculture land due to seepage and leakage has decreased the production of the crop. Shrimp farming is also done in the river /stream/canal areas without following any proper procedure and not using any scientific manner, and hence it is harming the natural the environment of these water bodies.

Table 3: Change detection/ transition matrix between 2008 and 2012

Land-cover category		2012												
		Ag	Bwtp	Nj	W	Tp	Sa	Sm	Sl	S	Fwtp	Vc	Wl	Total area (ha)
2008	Ag	47460.12	416.09					76.92			32.03	5.40		47990.56
	Bwtp		4234.13											4234.13
	Nj		3.07	291.88										294.98
	W		25.83		2304.36									2330.29
	Tp					963.73								963.73
	Sa		16.06				359.45	3.84						379.39
	Sm							18924.31						18924.31
	Sl		8.24							336.22				344.56
	S										1383.94			1383.94
	Fwtp		0.82									3674.35		3675.18
	Vc		15.60					1.67			0.90	1260.71		1278.97
	Wl												8.54	8.54
	Total area(ha)	47460.20	4719.86	291.88	2304.36	963.73	359.45	19006.74	336.22	1383.94	3707.55	1266.11	8.54	81808.58

Machinery are installed without any plan on the riverside for which some part of the surrounded land of river/stream/canal is affected badly and during high tide, the water flows to the agriculture land through the broken affected land. Many times polluted water of shrimp farming which consists of different chemical ingredients and harmful waste material is directly disposed into the nearest agriculture land and river/stream/ canals which disturbs the environmental balance.

Table 4: Change detection/ transition matrix between 2012 and 2016

Land-cover category		2016											Total area (ha)	
		Ag	Bwtp	Nj	W	Tp	Sa	Sm	Sl	S	Fwtp	Vc		Wl
2012	Ag	46044.90	1126.74					188.73			99.74			47460.20
	Bwtp		4719.85											4719.86
	Nj		0.88	290.67										291.88
	W				2304.36									2304.36
	Tp					963.73								963.73
	Sa		1.25				330.10	1.05	25.14		1.72			359.45
	Sm							19006.74						19006.74
	Sl		9.51						325.14		1.51			336.22
	S									1383.94				1383.94
	Fwtp		17.75								3689.76			3707.55
	Vc		18.97					5.78			1.17	1239.91		1266.11
	Wl												8.54	8.54
	Total area (ha)		46045.25	5895.40	290.67	2304.36	963.73	330.10	19202.34	350.28	1383.94	3794.21	1240.19	8.55

Table 5: Summary of the statistic of land cover conversion for the period 2008-2016

SI No	'From' class	'To' class	Area of conversion(ha)	Percentage(%) of conversion
1	Agricultural land	Bw tanks/ponds	1546.54	3.223
2	Agricultural land	Settlement	266.18	0.555
3	Agricultural land	Fw tanks/ponds	131.28	0.274
4	Vegetation cover	Bw tanks/ponds	31.35	2.451
5	River/ stream/ canal	Bw tanks/ponds	26.29	1.128
6	Sandy area	Scrub land	25.14	6.626
7	Fw tanks/ponds	Bw tanks/ponds	18.09	0.492
8	Scrub land	Bw tanks/ponds	17.75	5.152
9	Sandy area	Bw tanks/ponds	17.30	4.561
10	Vegetation cover	Settlement	6.92	0.541
11	Sandy area	Settlement	4.89	1.289
12	Nayanjuli	Bw tanks/ponds	3.95	1.340
13	Vegetation cover	Fw tanks/ponds	2.07	0.162
14	Sandy area	Fw tanks/ponds	1.77	0.466
15	Scrub land	Fw tanks/ponds	1.61	0.467
16	Agricultural land	Vegetation cover	1.52	0.003

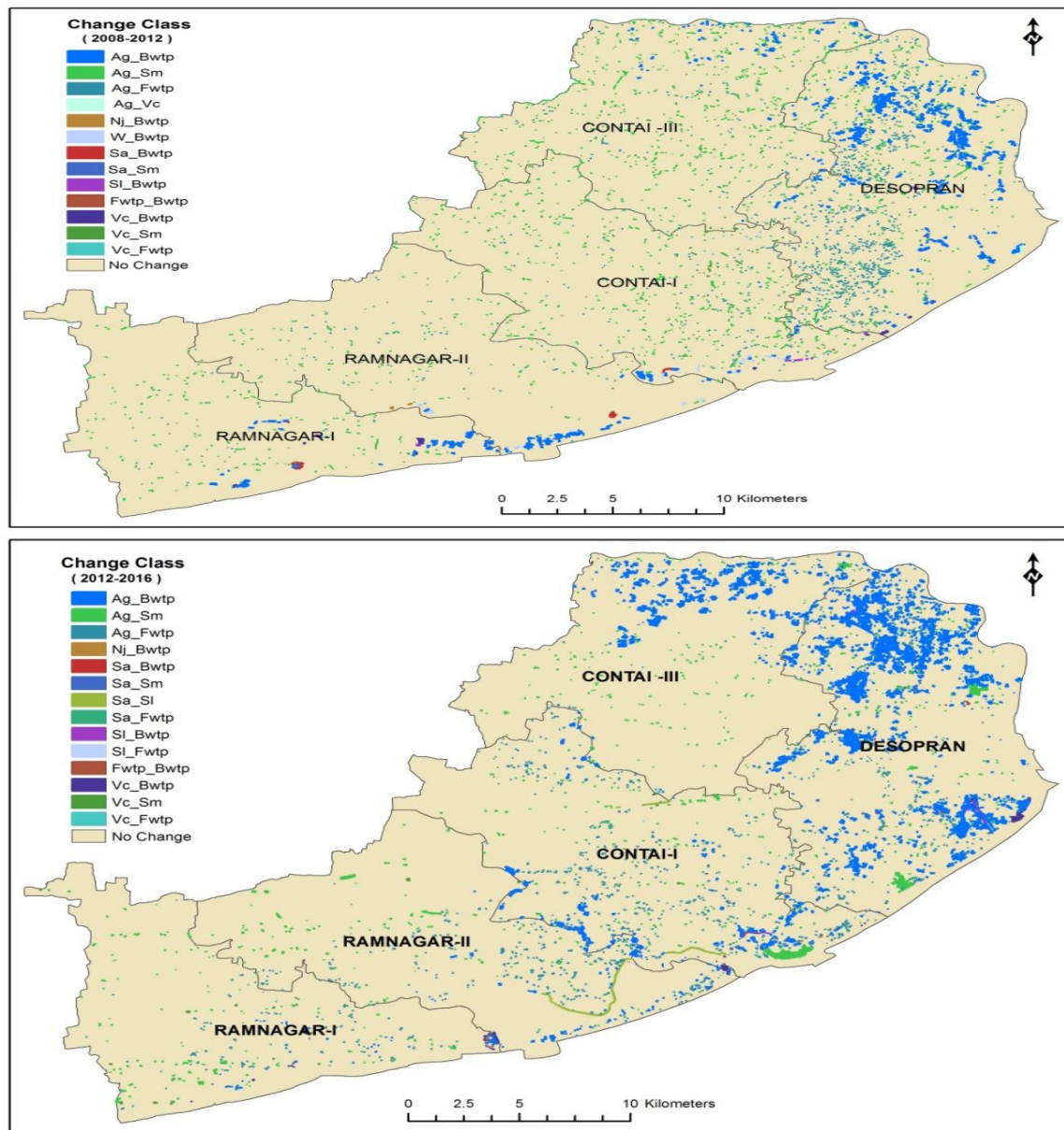

Figure 5: Land cover change map for the periods (a) 2008-2012, (b) 2012-2016

CONCLUSION

Due to market demand and high earning opportunities the shrimp farming is rapidly increasing in coastal areas, which was easily described in the present study with the help of remote sensing and GIS technique by analyzing multi-temporal satellite imageries. Local people have already realized its high-profit percentage which is much higher compared to rice and hence they have started doing shrimp farming blindly focusing just on money and not following any proper measures. The present study which is focused on five coastal blocks of Purba Medinipur district,

West Bengal, has found that during less period (8 years) of a total 1546.54 ha agriculture land has been converted to shrimp farming land. It is definite that this increase in shrimp farming industry is contributing to the economic growth of the country but this unplanned shrimp culture has badly affected the agriculture area and dis-balanced the environmental conditions. In India, we even have legal rules and restrictions of doing shrimp farming in a proper way without causing much harm to the environment, but those rules are not noticeably followed anywhere. Today researchers are really concerned about this environmental degradation and trying to spread awareness about this matter with regular publications and writings about the concerned topic. But if the administration still cannot understand the threat, they are definitely going to face it's consequences sooner or later.

ACKNOWLEDGMENTS

The authors are grateful to Amit Ghosh (Research Scholar, Jadavpur University, West Bengal) for giving time to time support and advice. The authors are also thankful to Biswajit Das and Pranab Khatua (TA, Forest Survey of India), Mahasweta Mukherjee (JRF, Fisheries Mapping Project Unit, Govt. of West Bengal) and Mayuri Borah (Research and Development Engineer, TECL) for their valuable technical advice.

REFERENCES

1. Riebsame, W.E. Mayer, W.B. and, Turner, B.L. II. Integrated modelling of land use and cover change. *Bioscience*.1994; 44(1): 350-362.
2. Vadlapudi, S. Identification and quantification of changes in mangrove forest using remote sensing in Kakinada Bay, Andhra Pradesh, India. *GIS development*.1996; 1-9.
3. Hossain, M.Z. Muttitanon, W. Tripathi, N.K. and Phillips, M. Monitoring Shrimp farming development from space. *GIS Development*. 2003; 1-6.
4. Rajitha, K. Mukherjee, C.K. and Vinu Chandra, R. Application of Remote sensing and GIS for sustainable management of shrimp culture in India. *Journal of Aquaculture Engineering*.2007; 36:1-17
5. Ojha, A. Chakrabarty, A. Village level land use land cover change dynamics and brackish water aquaculture development: a case study in Desopran block, West Bengal, India using multi-temporal satellite data and GIS techniques. *International Journal of Remote Sensing & Geoscience*, 2016; 5: 13-18.
6. Shang, Y.C. Leung, P. Ling, B.H. Comparative economics of shrimp farming in Asia. *Aquaculture* . 1998; 164 (1-4): 183-200.

7. Dewalt, B. Vergne, P., Hardin, M. Shrimp aquaculture development and the environment: people, mangroves and fisheries on the Gulf of Fonseca, Honduras. *World Development*.1996;24 (7): 1193–1208.
 8. Flaherty, M. Vandergeest, P. Miller, P. Rice paddy or shrimp pond: tough decisions in rural Thailand. *World Development*.1999;27 (12): 2045–2060.
 9. Hossain, S. Alam, S.M.N. Lin, C.K. Demaine, H., Khan. Y.S.A. Das, N.G. Roup, M.A. Integrated management approach for shrimp culture development in the coastal environment of Bangladesh. *World Aquaculture* 2004; 35 (4): 35–44.
 10. Singh, A. Digital techniques using remotely sensed data. *International Journal of Remote Sensing*. 1989;10: 989-1003.
 11. Rajitha, K. Mukherjee, C.K and Vinu Chandra, R. Land-cover change dynamics and coastal aquaculture development: A case study in the East Godavari delta, Andhra Pradesh, India using multi-temporal satellite data. *International Journal of Remote sensing*. 2010; 4423-4442.
 12. Gupta, M.C. Krishnarajan, V.P. and ShaileshNayak.. Brackish water aquaculture site selection in coastal track of Cannanore (Kerala) using Remote Sensing and GIS techniques, *J. Ind. Soc. Remote Sensing*.2001; 29 (I&2):79-83.
 13. Laba M, Smith SD and Degloria SD. Landsat-based land cover mapping in lower Yuna River watershed in the Dominican Republic. *International Journal of Remote Sensing*.1997; 18: 3011-3025.
 14. Ali, A.M.S. Rice to shrimp: Land use/land cover changes and soil degradation in Southwestern Bangladesh, *Land Use Policy*.2006;23: 421–435.
 15. Turner, M.G. Costanza, R. and Sklar, F.H. Method to evaluate the performance of spatial simulation models. *Ecological Modelling*.1989;48: 1-18.
 16. Gupta, B.P. Krishnani, K. K.Joseph, K. O.Muralichthar, M. Nagavel , A. and Parimala, V. Studies on the Effect of Shrimp Farming on Adjacent Agricultural Land and Underground Water in Cuddalore District of Tamil Nadu, *Applied fisheries and aquaculture*.2002; 2(1) : 47-50.
-